

Model # 64-0500

Easy Assembly Instructions & Rules

Shot King™



DO NOT RETURN TO STORE.

**FOR ALL RETURNS AND WARRANTY
COVERAGE PLEASE CALL GLD
PRODUCTS:**

1-800-225-7593

Please provide model number, serial
number, and/or part number of the
product or part when you call.
Numbers can be found on outside
of packaging.

Featuring The

LEVELAL™

Leveling System

Patent # 6,132,320



This manual is provided to instruct you during the assembly of your new Fat Cat™ Shot King Pool Table. Please refer to it as necessary. Be sure to have another person help you assemble the table.

Careful handling of all parts during assembly will ensure many years of enjoyment!

Fat Cat™ Pool Tables use the patented Levelal™ table leveling system to assure your table remains level and continues to give you the finest playing surface in the industry.

Recommended room size for the Fat Cat™ Shot King Pool Table is 13' 4" x 16' 0" minimum.

★ **WARNING!** Make sure table is assembled on the spot where you plan to keep it. Do not attempt to move table after it is assembled. Sliding the table may cause it to collapse! ★

Tools

Assembly of the Fat Cat™ Shot King Pool Table requires the following common tools:

- Drill or screw gun with Phillips bit
- A drill bit for pilot holes
- Regular and Phillips screwdrivers
- Socket wrench kit
- Carpenter's level
- Tape measure
- Razor knife/Box cutter
- Scissors
- Fine grit sandpaper or emery cloth
- Several clean rags
- 2 sheets of folded paper
- Disposable cup
- Putty knife

★ **PRO TIP** ★ Arrange all of your tools before you begin assembly.

Unpacking

★ **PRO TIP** ★ Laying out parts in advance allows you to easily follow the assembly instructions.

Carefully remove all components and separate into the following groups:

1. **The Pedestal Group:** 2 (#21) leg panels, 2 (#22) leg post A, 2 (#23) leg post B, 2 (#25) leg center cross braces, 4 (#26) support blocks, 4 (#27) leg protectors, 4 (#28) leg levelers, 16 (#2) Phillips head screws, and 24 (#1) flat head screws.
2. **The Frame Group:** 2 (#29) side beams, 2 (#30) center cross beams, 2 (#32) end cross beams, 8 (#4) hex bolts, 8 (#8) hex bolts, 8 (#5) hex nuts, 8 (#7) spring washers, 24 (#6) black washers, 8 (#10) washers, 8 (#11) spring washers and 8 (#9) hex bolts.
3. **The Slate and Apron Group:** 3-piece (#33) slate set, 2 (#35) side aprons, 2 (#36) end aprons, 4 (#37) apron corner pieces, 24 (#12) screws, 16 (#20) slate screws, 4 (#31) wood plugs and 32 (#13) round head screws.
4. **The Cloth Group:** 1 piece of (#34) green cloth, 1 (#49) can of spray adhesive, and 1 (#50) bag of joint compound.
5. **The Rail and Pocket Group:** 2 (#38) side rail pieces, 2 (#39) end rail pieces, 4 (#40) end rail corner pieces, 6 (#41) drop pockets, 24 (#24) pocket nails, 18 (#18) hex bolts, 18 (#19) washers, 4 (#16) washers and 4 (#15) bolts.

Step 1: Assembling the Pedestals

For each pedestal, locate the predrilled holes on interior surface of each leg post. Line up predrilled holes in (#26) support blocks and attach to leg posts with 2 (#2) Phillips head screws. Repeat for all.

Next, slide 1 (#21) leg panel into the precut slot into 1 (#22) A and 1 (#23) B leg posts. Make sure bottom edge of panel is flush with bottom (tapered end) of leg posts. Insert 2 (#2) Phillips head screws into pre-drilled holes on the side of each leg post and secure to panel.

Place 1 (#25) leg center brace on top of (#26) support blocks on each leg assembly. Secure to leg assembly with 6 (#1) flat head screws. Repeat for other pedestal.

Flip both leg assemblies upside down and attach (#27) black leg protector to each corner with 3 (#1) flat head screws. Finish by inserting (#28) leg leveler into ferrule on each leg protector. Turn leg assemblies right side up.

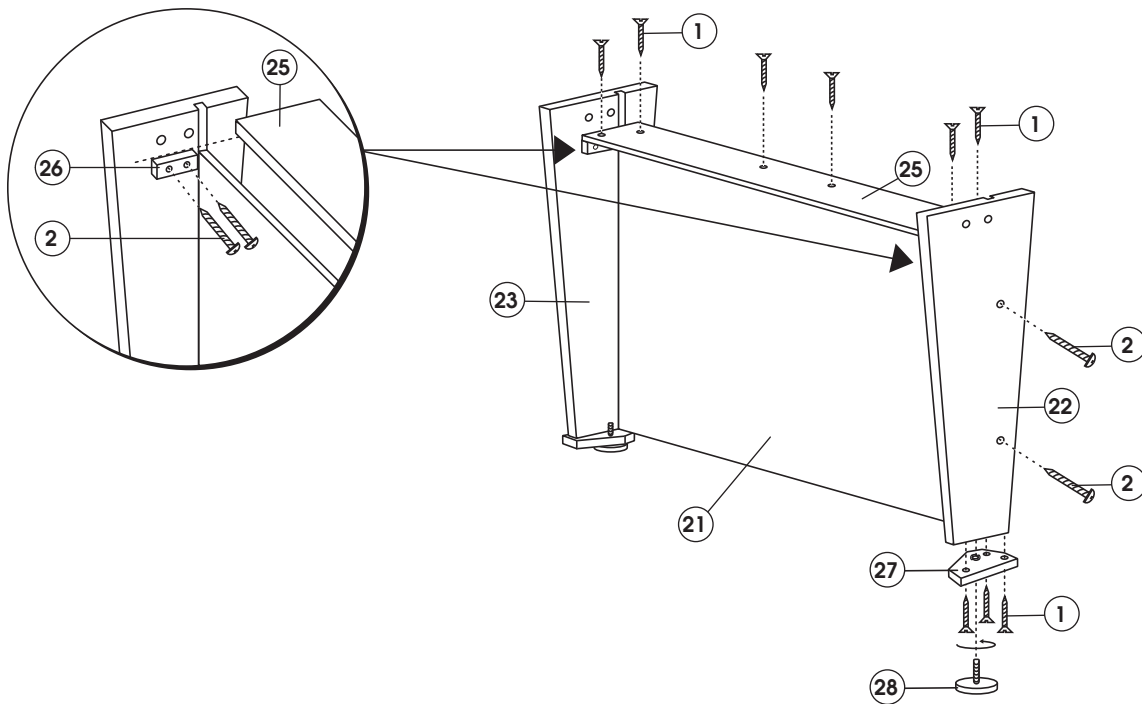

★ PRO TIP ★ To insure easy alignment of parts, assemble each section loosely before tightening down all screws/bolts in steps 2&3.

Step 2: Assembling the Base

With the help of another person, set both pedestals upright. (Slotted ends of pedestals face to the outside of table.) One at a time, place the 2 (#29) side beams in position on top of the pedestals, flat sides facing out, making sure pre-cut holes in beams are lined up with the 2 holes in the pedestals. Place (#6) black washer over the end of a (#4) hex bolt and insert through one of the holes in pedestal and side rail, then add another (#6) black washer and a (#7) spring washer. Finish with a (#5) hex nut and loosely secure. Repeat for opposite side of pedestal and then other pedestal. Follow the same procedure for the second hole. Note: It may be necessary to gently apply pressure to pedestals to allow holes to line up. Leave bolts loose until after step 3.

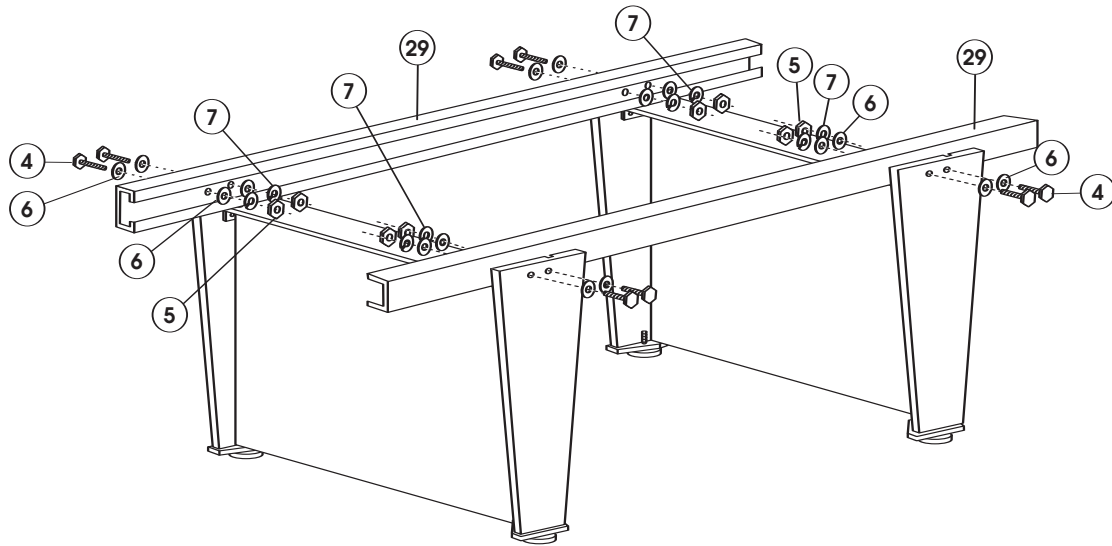

Step 3: Attaching the Slate Support Beams

Set (#32) end cross beams on top of side beams, lining up predrilled holes. Attach loosely with 8 (#8) hex bolts, 8 (#6) black washers, 8 (#10) washers, 8 (#11) spring washers, and 8 (#9) hex nuts. Repeat process for (#30) center cross beams. Tighten down all bolts to complete base frame.

Place table into position in your room (13' 4" x 17' 0" minimum). Measure ends at base frame to walls, making sure there is at least 60" between the table and the wall. You do not want to move the table after this step. Level base frame by placing level on cross beams and level side to side and front to back.

★ PRO TIP ★ A level base frame gives you the proper foundation for a level playing surface.

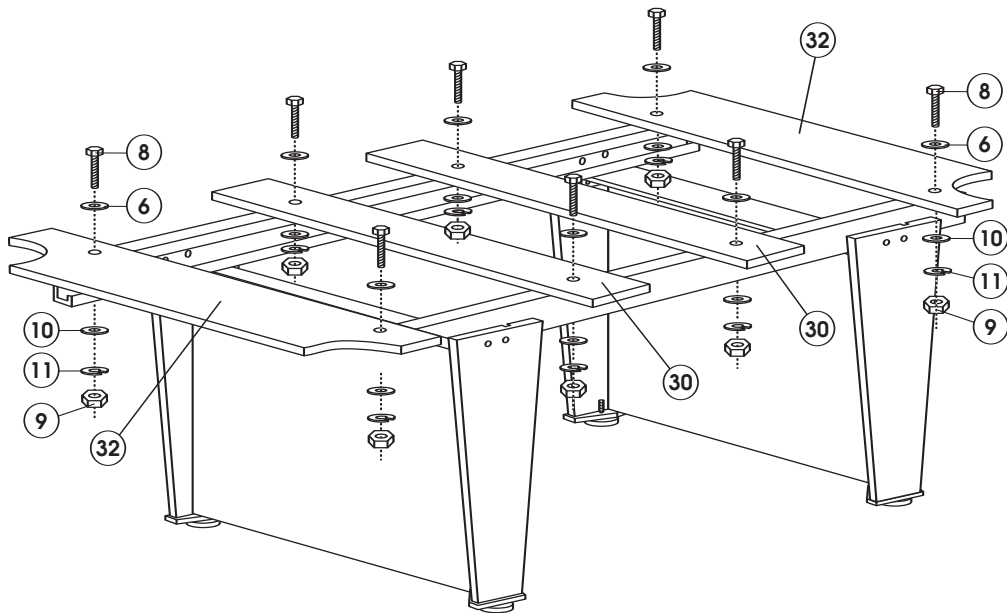

Step 4: Securing the Slate

With the help of another person, place the middle section of (#33) slate on the center supports of the base. Measure from the edge of slate to outer edge of end cross beams. Make sure this piece is centered perfectly, is square to all sides, and that the overhang is equal on both sides.

Place each end section of slate in position on the base. Check to make sure all sections are flat on the base. Double-check overhang and if necessary, adjust to make sure it is equal on all sides.

★ PRO TIP ★ The 3 sections of slate should be set tightly against each other to give the appearance of a solid table top. Slide a folded piece of paper into the joint between each end section and the middle section. This prevents the edges of the slate from sticking together and chipping while slate is being leveled.

Use the (#47) 3/8" Allen wrench to adjust each of the 16 slate levelers (already inserted in the slate by manufacturer) until all are flush with the base. **This is very important.**

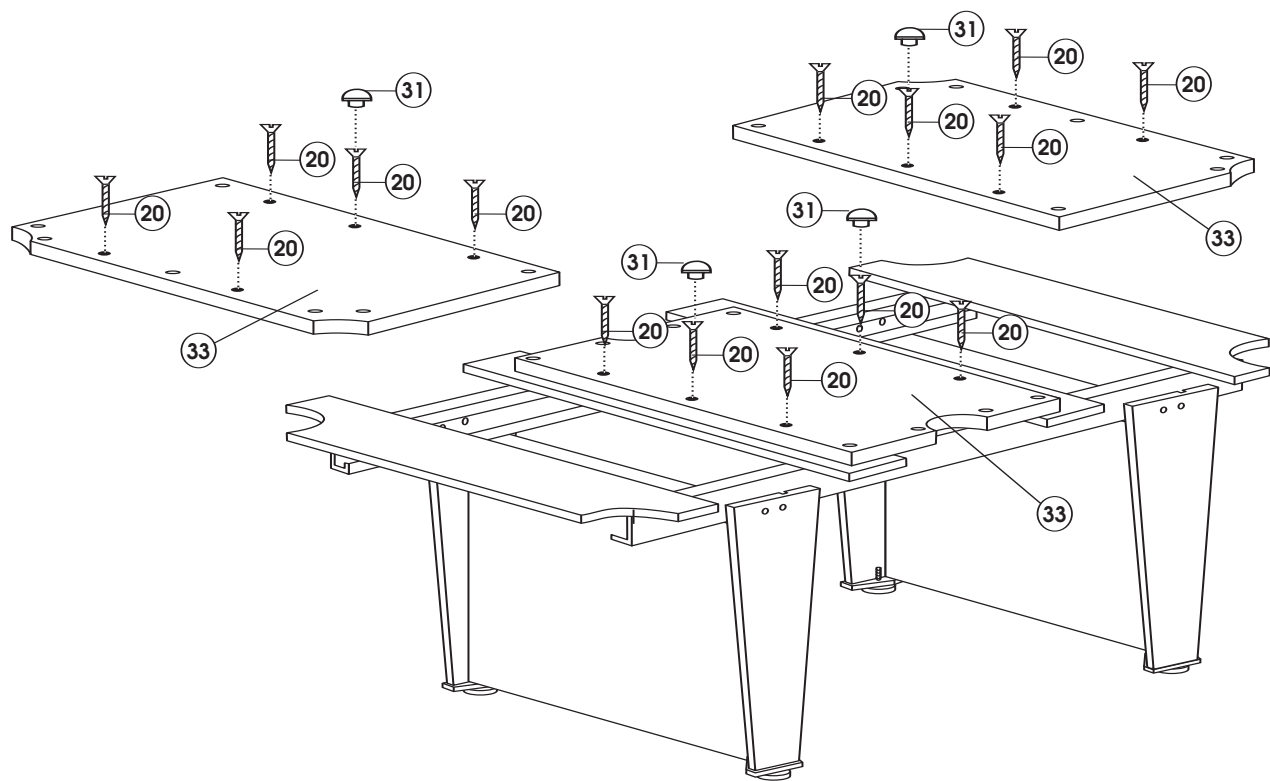

Step 5: Leveling the Slate

Using the carpenter's level determine which of the 3 sections is least level. Begin the leveling process with this section by adjusting the levelers with the (#47) Allen wrench. When it is level, set the other 2 sections to match it. Make sure the seams are smooth and all 3 sections are perfectly level. Double check the seams in several places with your level.

★ PRO TIP ★ To determine the seams are smooth, slide 2 fingers back and forth across the seams. Do not try to rush through this leveling process. All sections must be perfectly level if you want the highest quality playing surface.

With the drill bit, drill a pilot hole through each leveler opening into the base. Be careful to drill straight down. Insert the (#20) slate screws and fasten the slate to the base. Double check with the level to make sure all seams are still smooth and all surfaces are level. Any fine tuning can be done by slightly backing off the screws and readjusting the levelers with the (#47) Allen wrench.

Set a (#31) wood plug into each of the 4 leveling cavities nearest the center of the table (the 12 cavities on the outside perimeter do not require plugs since they are outside the playing field). Be sure to push the plug completely into the hole, flush with the table.

Mix a small amount of hardener and (#50) joint compound in a disposable cup.

★ PRO TIP ★ It is best to mix several small batches of joint compound as it sets quickly and becomes unworkable.

Using a putty knife apply the compound to the seam area, thinly spreading it toward you. Make sure the seam is filled completely. Also fill each of the 4 leveler/plug holes and any other imperfections in the surface.

Allow the compound to dry thoroughly. Lightly hand sand each area until smooth to the touch.

★ PRO TIP ★ Do not over-sand or use an electric sander. This can cause a "dip" in the slate and ruin the playing surface.

Step 6: Applying the Cloth

★ PRO TIP ★ Before applying the cloth make sure that slate has been wiped down and is free of any dirt or particles. Be sure your hands are clean before handling the cloth. Any adhesive residue may be removed from the cloth with duct tape.

Locate sticker on one side of (#34) cloth. This is the top side or playing surface. Unfold and center cloth, playing surface up, on top of the clean slate. Make sure the overhang is equal on all four sides.

Starting at one end of the table, fold the cloth over and expose about 3 inches of slate. Carefully spray a 1-1/2" wide strip of (#49) adhesive along the top edge of the slate. Also spray the outer edge, avoiding the pocket cut outs. Repeat this procedure at the opposite end. Allow the adhesive to set until tacky to the touch (usually several minutes).

After the adhesive has set, secure the cloth at one end of the table by starting in the middle and smoothly stretching the cloth out to each of the corner pockets.

Move to the center of the opposite end of the table. With one hand, pull the cloth tightly toward you until you have a 1-1/2" fold in the center of the cloth and with the other hand press it firmly into place. Pull the sides of the cloth tightly toward their respective corners. Smooth and press firmly, always working from center to corner.

Repeat this process on the sides of the table. Start from the center pocket on one side of the table and pull toward you, taking up half of the fold from the center of the cloth. Smooth into place working from the center out to the corner pockets. On the opposite side start from the center pocket and pull toward you, taking up the remaining fold from the center of the cloth. Smooth into place working from the center out to the corner pockets. The cloth should be smooth and tight. Using your scissors or box cutter, trim the cloth until even with the bottom edge of the slate.

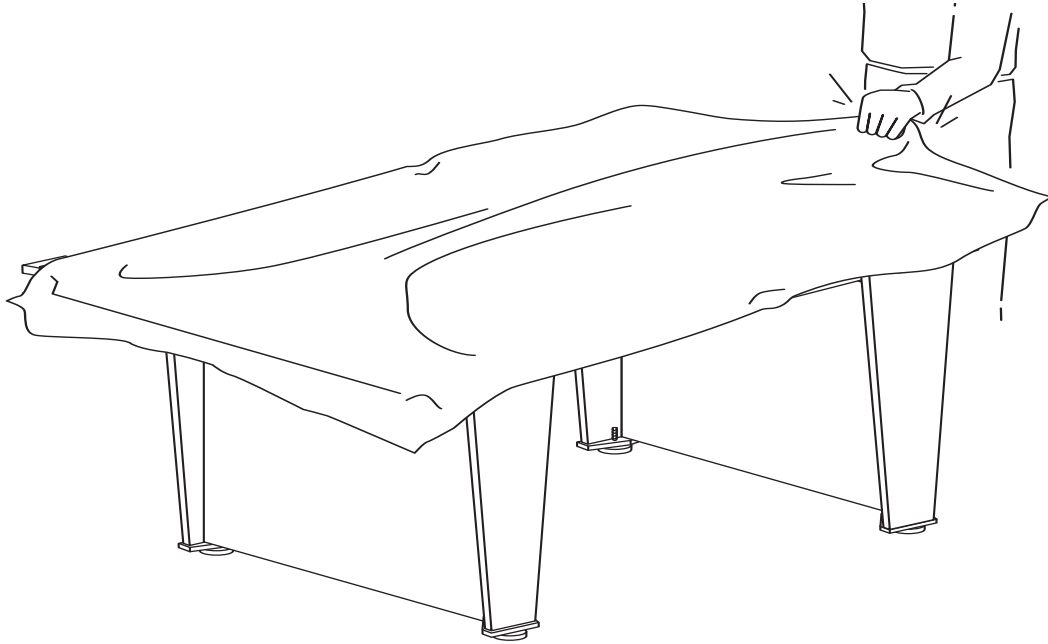

Carefully spray adhesive on the edge and underside of the pocket area. Also spray the underside of the cloth with adhesive.

Cut 3 pie shaped wedges in the cloth at the corner pocket cut outs. Fold cloth down and under to wrap cut out edges. Cut 5 pie shaped wedges in the cloth at the side pocket cut outs. Fold cloth down and under to wrap cut out edges.

★ PRO TIP ★ Be very careful to not cut past the table's top edge and into the playing surface when cutting the wedges.

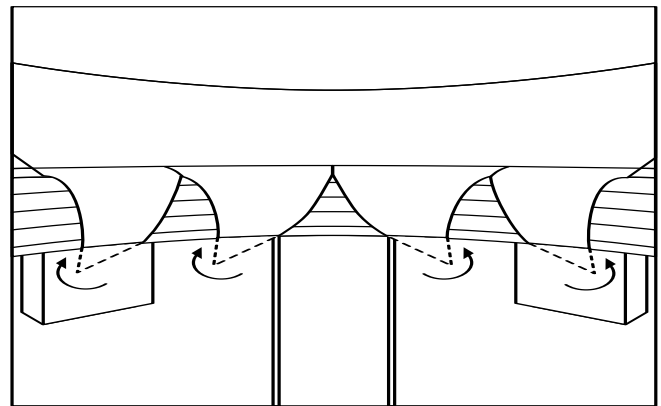
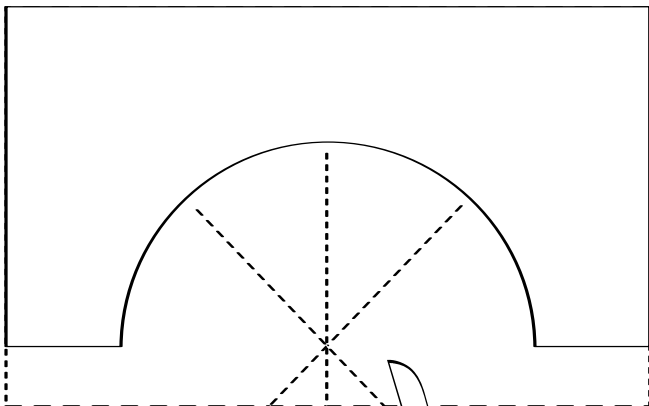

Press the cloth firmly against the slate along the curve of all pockets. Trim off excess cloth with scissors or box cutter.

Locate the 18 holes for the rail bolts along the perimeter of the tabletop. Carefully punch holes in the cloth.

★ PRO TIP ★ Using a Philips screwdriver, run the shaft of the screwdriver around the sharp edge of the holes in the slate. This gives the perfect hole. Be careful not to punch through slate screw holes.

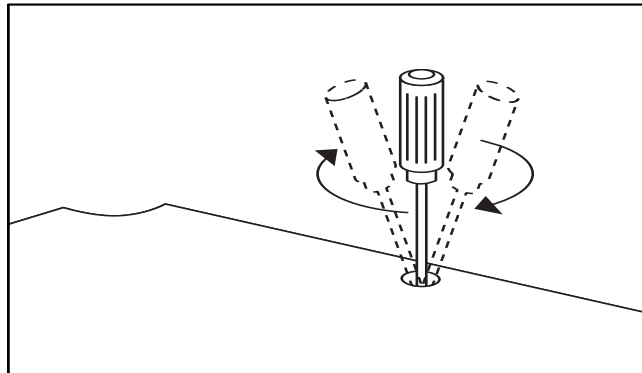

Step 7: Attaching the Apron

With the help of another person, place (#35) apron section on side of table, making sure the apron is centered to slate. Fix to base with 4 (#12) flat head screws. Repeat process for other apron sections.

Slide the (#37) apron corner onto each side of the (#36) end apron and fasten with 8 (#13) screws. Place the end apron onto the table and secure the apron corner to the (#35) side apron with 4 (#13) screws. Fasten the end aprons and side aprons to the table with 4 (#12) flat head screws. Repeat for other half.

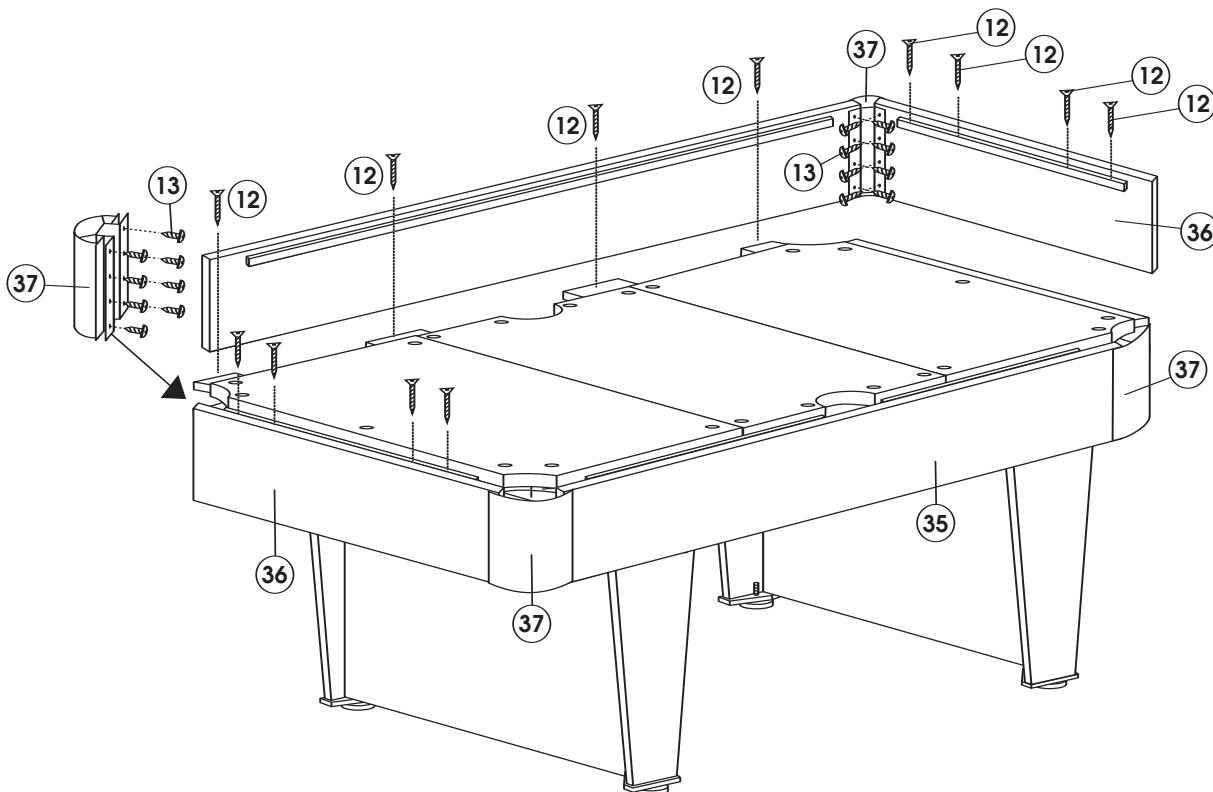





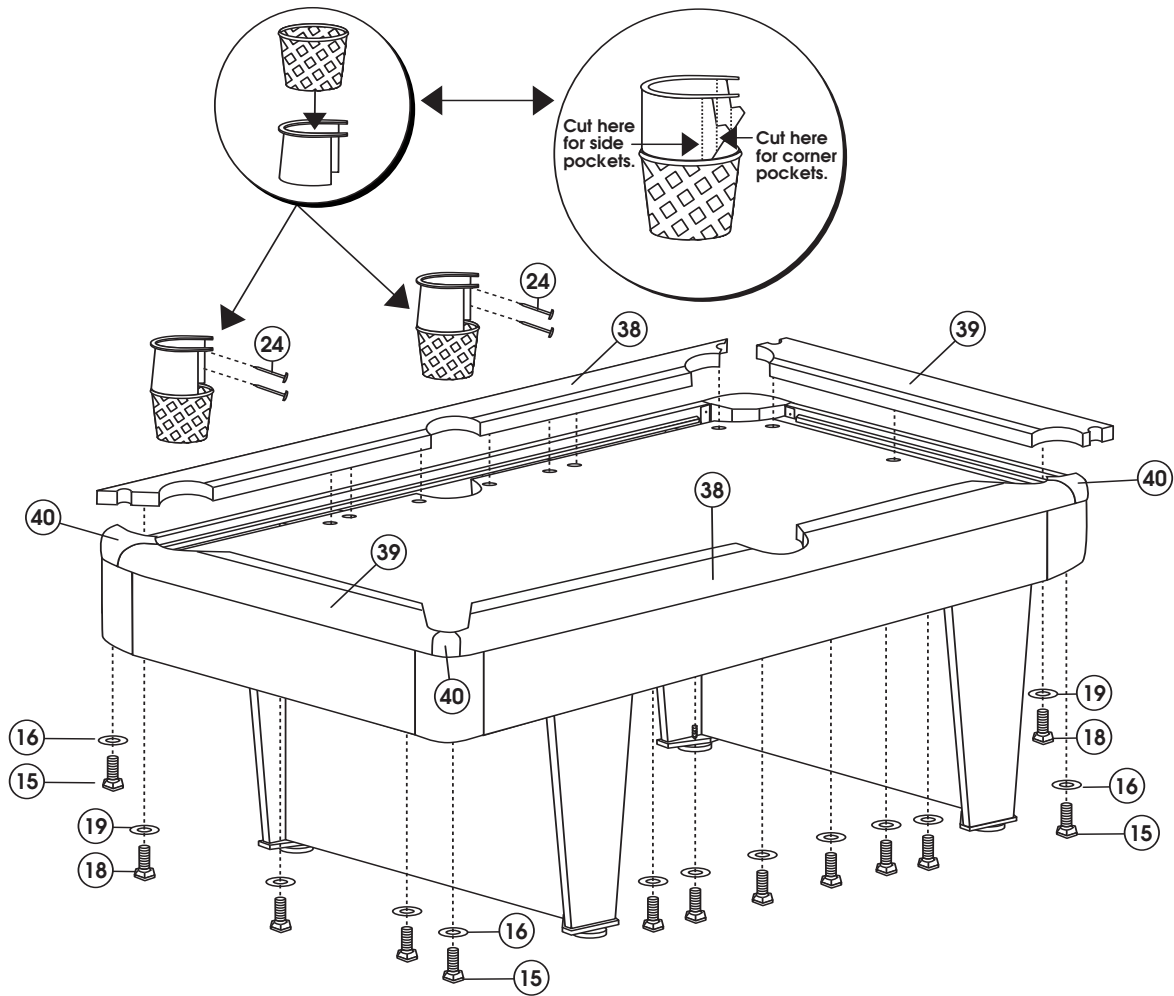





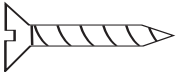
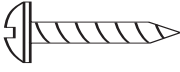

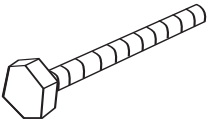

Step 8: Assembling Rails and Pockets

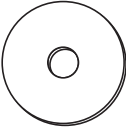
Set all rail pieces into position on table top. Loosely attach (#38) side rail section to base on the underside of table with (#18) hex bolts and (#19) washers. Loosely attach (#39) end rails in same manner. Slide (#40) corner pieces on loosely. Adjust rail fit as needed. Secure corners on underside of table with (#15) bolts and (#16) washers. Tighten all rail bolts securely. Snap drop pockets together, cut as indicated, insert into pocket cutouts in the table and secure with (#24) pocket nails. Make sure rails are square and straight w/respect to the pockets and slate.

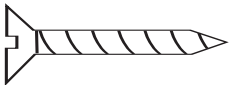

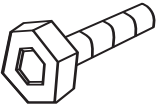

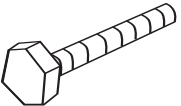
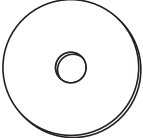
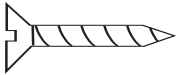
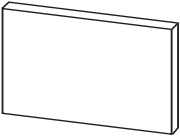

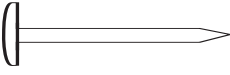
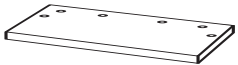
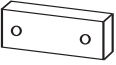
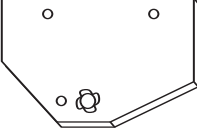



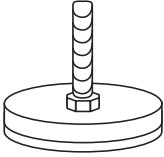
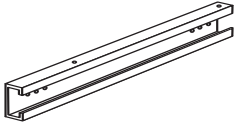

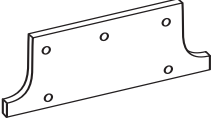
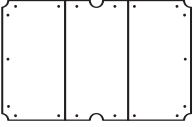

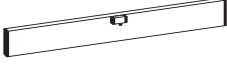

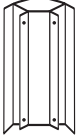
YOU ARE NOW READY TO PLAY!

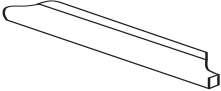
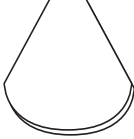
Fat Cat™ Shot King Pool Table Parts List

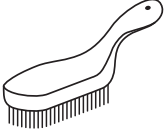
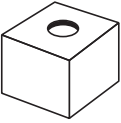
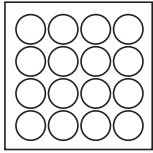
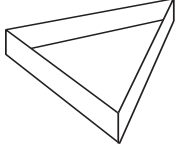
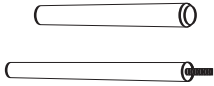
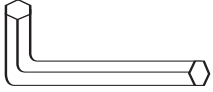
| | | | | |
|---|--|--|--|---|
| <p>#1.</p>  <p>#8 x 1-1/4" Flat Head Screw 24 Pieces</p> | <p>#2.</p>  <p>#8 x 1-1/2" Phillips Head Screw 16 Pieces</p> | <p>#4.</p>  <p>3/8" x 2-1/2" Hex Bolt 8 Pieces</p> | <p>#5.</p>  <p>3/8" Hex Nut 8 Pieces</p> | <p>#6.</p>  <p>3/8" x 1" Black Washer 24 Pieces</p> |
| <p>#7.</p>  <p>3/8" x 14mm" Spring Washer 8 Pieces</p> | <p>#8.</p>  <p>5/16" x 2-1/2" Hex Bolt 8 Pieces</p> | <p>#9.</p>  <p>5/16" Hex Nut 8 Pieces</p> | <p>#10.</p>  <p>5/16" x 23mm Washer 8 Pieces</p> | <p>#11.</p>  <p>5/16" x 14mm Spring Washer 8 Pieces</p> |
| <p>#12.</p>  <p>#8 x 1-1/2" Flat Head Screw 24 Pieces</p> | <p>#13.</p>  <p>T4 x 1/2" Round Head Screw 52 Pieces</p> | <p>#15.</p>  <p>1/4" x 1/2" Allen Bolt 4 Pieces</p> | <p>#16.</p>  <p>1/4" x 32mm Washer 4 Pieces</p> | <p>#18.</p>  <p>5/16" x 1-3/4" Hex Bolt 18 Pieces</p> |
| <p>#19.</p>  <p>5/16" x 35mm Washer 18 Pieces</p> | <p>#20.</p>  <p>#12 x 2" Slate Screw 16 Pieces</p> | <p>#21.</p>  <p>Leg Panel 2 Pieces</p> | <p>#22.</p>  <p>Leg Post A 2 Pieces</p> | <p>#23.</p>  <p>Leg Post B 2 Pieces</p> |
| <p>#24.</p>  <p>Pocket Nails 24 Pieces</p> | <p>#25.</p>  <p>Leg Center Brace 2 Pieces</p> | <p>#26.</p>  <p>Support Block 4 Pieces</p> | <p>#27.</p>  <p>Leg Protector 4 Pieces</p> | |

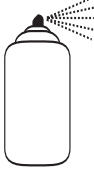
Fat Cat™ Shot King Pool Table Parts List (continued)

| | | | | |
|--|--|--|--|---|
| <p>#28.</p>  <p>Leg Level 4 Pieces</p> | <p>#29.</p>  <p>Side Beam 2 Pieces</p> | <p>#30.</p>  <p>Center Cross Beam 2 Pieces</p> | <p>#31.</p>  <p>Wood Plug 4 Pieces</p> | <p>#32.</p>  <p>End Cross Beam 2 Pieces</p> |
| <p>#33.</p>  <p>Slate Set 3 Pieces</p> | <p>#34.</p>  <p>Cloth 1 Piece</p> | <p>#35.</p>  <p>Side Apron 2 Pieces</p> | <p>#36.</p>  <p>End Apron 2 Pieces</p> | <p>#37.</p>  <p>Apron Corner 4 Pieces</p> |
| <p>#38.</p>  <p>Side Rail 2 Pieces</p> | <p>#39.</p>  <p>End Rail 2 Pieces</p> | <p>#40.</p>  <p>End Rail Corner 4 Pieces</p> | <p>#41.</p>  <p>Drop Pocket 12 Pieces</p> | <p>#42.</p>  <p>Felt Brush 1 Piece</p> |
| <p>#43.</p>  <p>Chalk 2 Pieces</p> | <p>#44.</p>  <p>Billiard Balls 1 Set</p> | <p>#45.</p>  <p>Triangle 1 Piece</p> | <p>#46.</p>  <p>2 Cue Sticks 4 Pieces</p> | <p>#47.</p>  <p>Allen Wrench 1 Large, 3 Small</p> |
| <p>#48.</p>  <p>Wrench 1 Piece</p> | <p>#49.</p>  <p>Spray Adhesive 1 Can</p> | <p>#50.</p>  <p>Joint Compound 1 Bag</p> | | |

WARRANTY INFORMATION

1 Year Warranty on Shot King™ Pool Table

Manufacturer warrants to the original retail purchaser, this product to be free from defects in material and workmanship for a period of one (1) year from the date of purchase.

For ten (10) years from the date of purchase for slate, we will repair the playing surface of this table, free of charge, if it fails to remain flat, within a tolerance of $\pm 30/1000$ of an inch, measuring from any flat plane within the playing surface. Note: Cloth not included in warranty. Should this product become defective due to material or workmanship within the warranty period, contact our Customer Service Department. This warranty is not transferable and does not cover normal wear and tear, or damage caused by improper handling, installation or use of this product. This warranty is also void if product is in any way abused, damaged or modified from its original state, or if used for other than indoor residential use. This warranty gives you specific legal rights and you may have other rights which vary from state to state.

DO NOT RETURN TO STORE

For all returns and warranty coverage, please call:

GLD Products

1-800-225-7593

Please provide model number, serial number and/or part number when you call. Numbers can be found on outside of packaging.



GLD Products

S84 W19093 Enterprise Drive

Muskego, WI 53150 USA

800 225 7593 • FAX 800 841 6944

Email: gld@gldmfg.com