

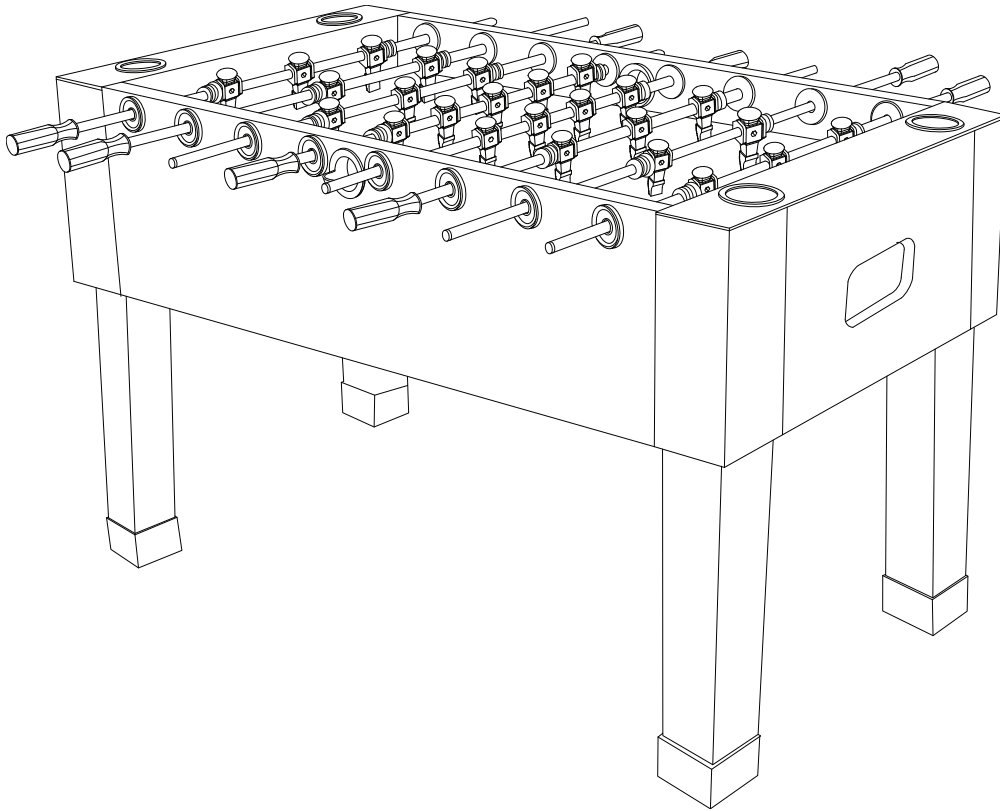

Maverick Foosball Table

Item 64-0907

MAVERICK FOOSBALL TABLE



Replacement Parts

Order direct at www.gldproducts.com
or call our Customer Service department at
(800) 225-7593
8 am to 5 pm Central Standard Time

Staple your receipt here.

Important: A copy of your receipt will be needed to activate your warranty (see page page 12)

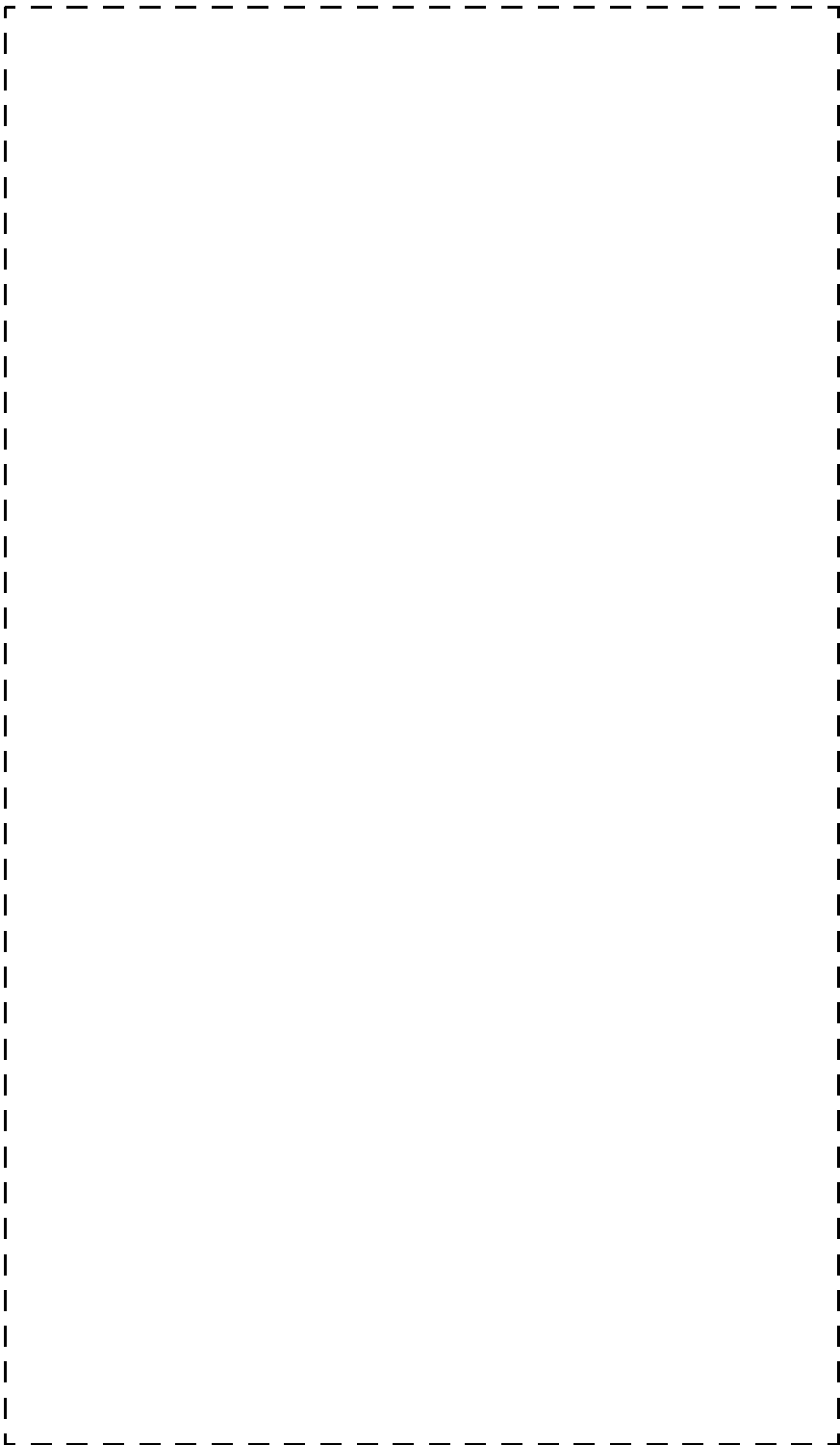



Congratulations and THANK YOU for purchasing the Maverick Foosball Table. You have chosen a product that should provide years of entertainment. To assist you with customer service and warranty claims, staple your receipt to the inside cover, then keep this manual in a safe place for future reference.

GLD Products











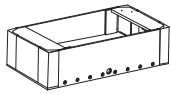
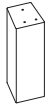

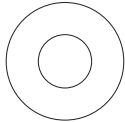

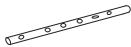
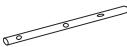
S84 W19093 Enterprise Drive
Muskego, WI 53150 USA
1-800-225-7593
Fax: 1-800-841-6944
Email: gld@gldmfg.com
Web: www.gldproducts.com

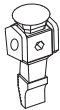
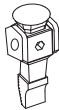
This manual may have been updated. For the latest manual visit the GLD products website.

	<p>Place your package near the location where it will be used. Carefully unpack all components and verify you have all the correct pieces.</p> <p>If you notice missing or defective parts, please call us at: 1-800-225-7593.</p>
---	---

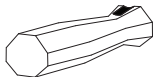
	<p>Please read and understand all instructions before beginning assembly.</p> <p>This assembly will require 2 adults.</p> <p>This product is not for use by children without adult supervision.</p>
---	--

Parts Identifier

Part No./ Qty	Illustration/ Order Number	Part No./ Qty	Illustration/ Order Number	Part No./ Qty	Illustration/ Order Number
1 Qty. 1	 Main Cabinet Order No. 64-0907-01	2 Qty. 4	 Leg Order No. 64-0907-02	3 Qty. 8	 Lock Nut 8 mm Order No. 3-161
4 Qty. 8	 Washer 8 x 19 mm Order No. 3-162	5 Qty. 26	 Bolt 4 x 28 mm Order No. 64-0907-05	6 Qty. 26	 Lock Nut 4 mm Order No. 2-110
7 Qty. 2	 5 Player Rod 15.8 mm Order No. 64-0907-07	8 Qty. 2	 2 Player Rod 15.8 mm Order No. 64-0907-08	9 Qty. 4	 3 Player Rod 15.8 mm Order No. 64-0907-09
10 Qty. 13	 Black Player 15.8 mm Order No. 64-0907-10	11 Qty. 13	 Gray Player 15.8 mm Order No. 64-0907-11	12 Qty. 16	 Bumper 15.8 mm Order No. 64-0907-12
13 Qty. 16	 Plastic Washer 15.8 x 38 mm Order No. 64-0907-13	14 Qty. 8	 Rod End Cap 15.8 mm Order No. 64-0907-14	15 Qty. 8	 Plastic Handle Order No. 64-0907-15
16 Qty. 2	 Slide Scorer Order No. 64-0907-16	17 Qty. 4	 Flat Countersunk Screw 4 x 18 mm Order No. 3-163	18 Qty. 4	 Soccer Ball Order No. 64-0907-18
19 Qty. 1	 Wrench Order No. 64-0907-19				

IF YOU HAVE A WARRANTY CLAIM, CALL US FIRST

Please see page 11.

GLD Products

Available 8 am to 5 pm Central Standard Time

S84 W19093 Enterprise Drive
Muskego, WI 53150 USA
1-800-225-7593
Fax: 1-800-841-6944
Email: gld@gldmfg.com
Web: www.gldproducts.com

For all claims, please have your receipt and item number when you call. The product item number can be found on the front cover.

If you are instructed to return the product for service, you are responsible for shipping the unit at your expense.

PRODUCT REGISTRATION

Important: The product registration form on page 12 and a copy of your receipt must be completed and returned within 10 days of purchase to validate your warranty.

Preparing for Assembly

- Be sure to unpack all of the parts included in this package. Some parts may be in obscure locations of the packaging. Check inside any tubes or sleeves. Save all packing material until the product is fully assembled and functional.
- Compare the parts in your package with the Parts Identifier description on page 4.
- After unpacking large products, some disassembly may be required prior to beginning the assembly.

Tools Required

- Wrench (#19) - Included with table
- Phillips screwdriver (not included)
- Level (not included)
- Electric screwdriver may be helpful. CAUTION: You must set at LOW TORQUE and use extreme caution because you could overtighten the hardware, strip the screws, or damage the table.
- Rubber mallet or hammer (not included)

Assembly Tips

Make sure you understand the following before you begin to assemble your pool table.

1. READ THIS MANUAL all the way through before beginning assembly.
2. When installing parts that have more than one bolt, start ALL bolts in that part by hand before tightening anything.
3. Some drawings or images in this manual may not look exactly like your product.
4. You will need a second adult to assist with this assembly.

Note: Save all packing materials until the parts have been inspected and the table is assembled.

Unpack the Pieces

- Lay the box on a flat surface (floor). You may want this near your area of assembly.
- Unpack the boxes and part bags. Inspect and count the parts. The Parts Identifier page can be used to record your results.
- If any parts are damaged or missing contact GLD customer service.
- Missing fasteners may be purchased at a hardware store using the descriptions on the Parts Identifier page(s).

STEP 1 - ATTACH LEGS

- 1. Place the main cabinet (#1) assembly bottom up on the floor.
- 2. Position the four legs (#2) with the studs in the holes of the cross brace.
- 3. Use two washers (#4) and two nuts (#3) to secure each leg (#2).

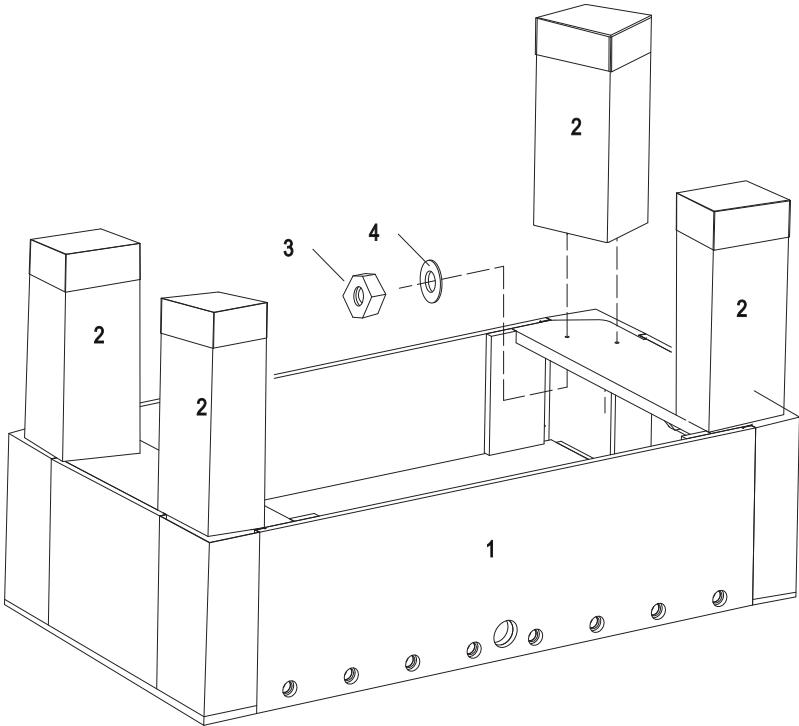

STEP 2 - TURN BASE OVER

The base assembly is ready to be turned over.

USE AT LEAST TWO PEOPLE TO LIFT THE BASE ASSEMBLY AND TURN IT OVER TO REST ON THE LEGS.

DO NOT ROLL THE TABLE OVER. This will place a sideways force on the legs. The legs should be off the floor until the base assembly is rotated completely. Set the base assembly down.

If visually the leg positions need adjusting, loosen the bolts, adjust, and retighten.

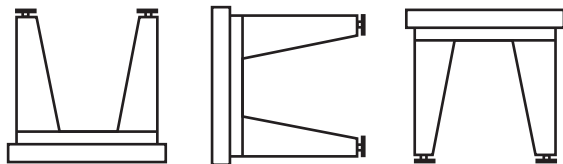
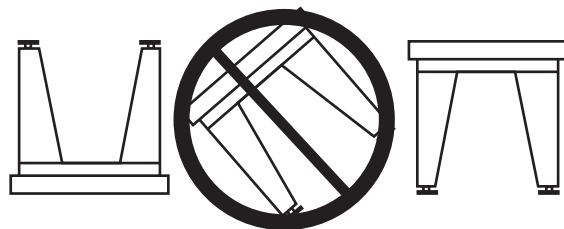
DO THIS**NOT THIS****STEP 3 - ATTACH PLAYERS**

1. Identify the position of the player rods by the number of holes in the rod. The top view will help to locate correct positions.
2. Assemble the handles (#15) to the player rods. Find the end of the player rod that has a hole approx. 6 inches from the end. Stand the rod up and place the handle (#15) over the end. Use a mallet to hammer the handle onto the rod.
3. Insert the end of the player rod (#7, #8 or #9) into the correct bushing on the side of the table.

NOTE: The handles for each color team will be on the same side.

4. Slide a bumper (#12) followed by a washer (#13) onto the rod.
5. Select the players (#10 or #11) onto the rod. The “feet” may not have the same shape on both sides. All players should face the opponents goal.
6. After the last player is on the rod, place a plastic washer (#13) then a bumper (#12) onto the rod. Push the end of the rod into the second bushing.

NOTE: The player rod should spin freely even though the players are not secured in place.

7. Secure the players (#10 or #11) to the player rod using a bolt (#5) and a lock nut (#6). Tighten to keep the players from moving.
8. On the end of the player rod away from the handle, push an end cap (#14) over the rod.
9. Repeat for the remaining player rods. Pay attention to team colors and foot direction.

10. Position the two slide scorers (#16) above the goals. Use two screws (#17) in each one to secure it to the table.

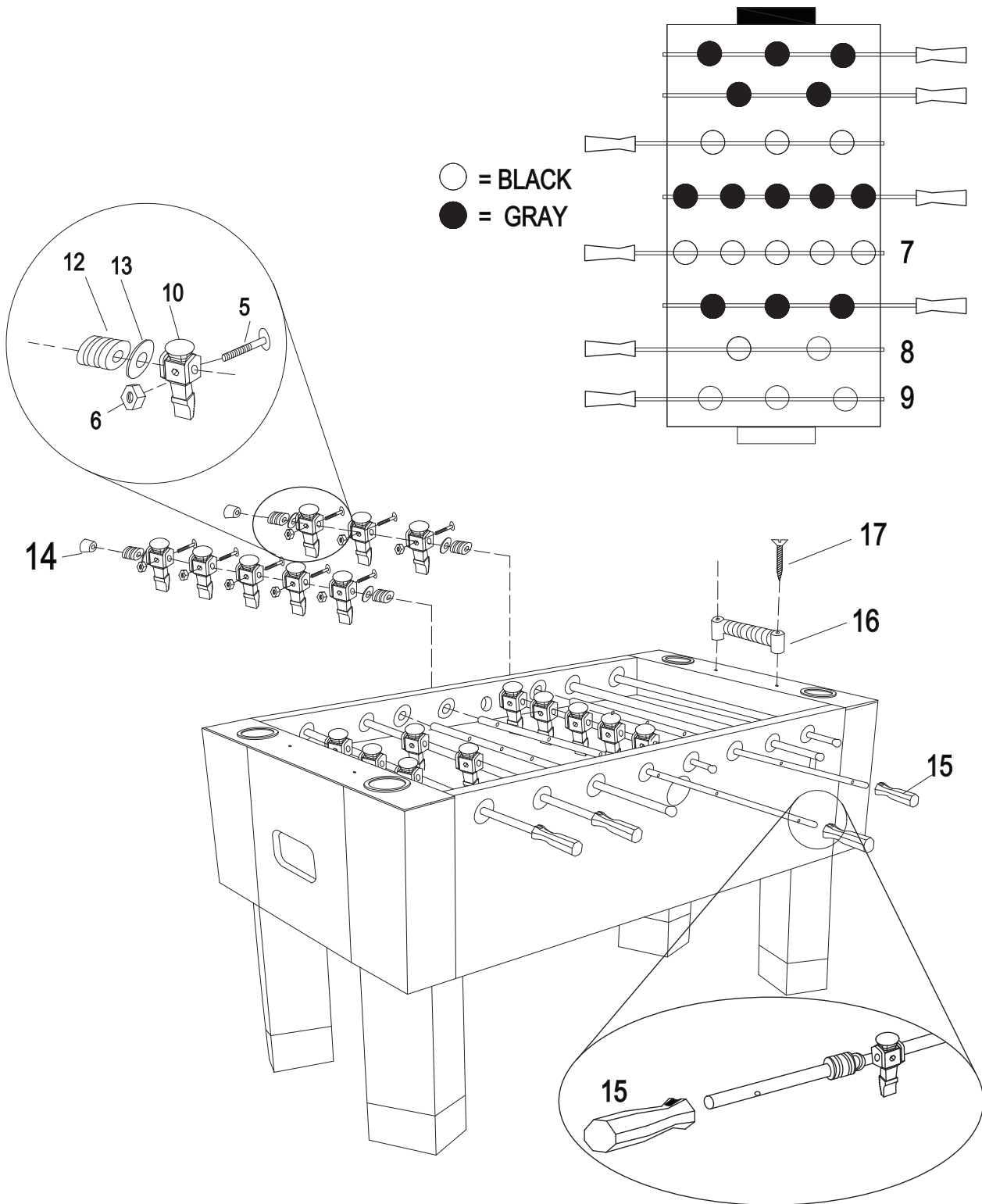

STEP 4 - LEVEL THE TABLE

1. Use a carpenters level and place shims or spacers under the legs as needed. Only basic leveling (if any) is needed as this is a fast game and the ball is always moving.

Care and Use of your Table

- This product is intended for INDOOR use only.
- DO NOT sit, climb, or lean on the table.
- DO NOT drag the table when moving it. This will damage the legs.
- To clean the hard surfaces spray a cloth with a mild cleaner and wipe.

90-DAY LIMITED WARRANTY

The Manufacturer warrants to the original retail purchaser that this product is free from defects in material and workmanship under normal use and conditions for a period of ninety (90) days from the date of original purchase. The Manufacturer's liability is limited to the repair or replacement, at its option, of any defective product and shall not include any liability for indirect, incidental or consequential damages of any kind.

Should this product become defective due to material or workmanship within the warranty period, contact our Customer Service Department. This warranty is not transferable and does not cover normal wear and tear or damage caused by improper usage, negligence, misuse, abuse, transportation damage, acts of nature, or accident (including failure to follow the instructions in this manual). It does not cover expendable items such as batteries, light bulbs, fuses, accessories, cosmetic parts and other items that wear out due to normal usage. This warranty is also void if the product is disassembled and reassembled, damaged, modified from its original state, or used for other than indoor personal residential use (no commercial or rental applications).

This warranty gives you specific legal rights, and you may have other rights which vary from state to state.

IF YOU HAVE A WARRANTY CLAIM, CALL US FIRST (8 - 5 CST)

Please have your receipt and item number (found on the front cover) when you call.

GLD Products

S84 W19093 Enterprise Drive
Muskego, WI 53150 USA
1-800-225-7593
Fax: 1-800-841-6944
Email: gld@gldmfg.com
Web: www.gldproducts.com
Web: www.GLDProducts.com

If you are instructed to return the product for service, you are responsible for shipping the unit at your expense to the above address in packaging that will protect against further damage. All warranty or repair requests require a Return Authorization Number prior to returning the item.

PRODUCT REGISTRATION

Important: The product registration form on page 12 must be completed and returned along with a copy of your receipt within 10 days of purchase to validate your warranty.

REGISTER YOUR PRODUCT

Place postage here

Complete this form, include a copy of your receipt, fold, tape (do not staple) and return within 10 days of purchase. This protects your warranty and will help us develop new products!

Cut here.

GLD Products
Warranty Department
S84 W19093 Enterprise Drive
Muskego, WI 53150 USA

Fold here second.



P R O D U C T S

www.gldproducts.com

GAME TABLES	HOME CASINO
GAMES AND ACCESSORIES	BILLIARD CUES
BILLIARD ACCESSORIES	DARTBOARDS
SOFT-TIP DARTS	STEEL-TIP DARTS
FLIGHTS AND SHAFTS	DART CASES AND ACCESSORIES

Fold here first.

Name	Date of Purchase
Address	Phone-Day
City	Phone-Evening
State	Zip
	Email
Purchase Price:	Item: 64-0907 Maverick Foosball
Store Name:	

Remember to attach a copy of your receipt.

Mail To: GLD Products
 S84 W19093 Enterprise Drive
 Muskego, WI 53150 USA
 1-800-225-7593 • FAX 800-841-6944
 Email: gld@gldmfg.com
 Web Site: www.gldproducts.com

Maverick Foosball Table

Item 64-0907

Parts Re-Order Form

Name		Date
Address		Phone-Day
City		Phone-Evening
State	Zip	Email

Order No.	Description	Unit Price Each	Qty.	Total Amount
64-0907-01	Main Cabinet	400.00		
64-0907-02	Leg	40.00		
3-161	Lock Nut 8 mm	0.50		
3-162	Washer 8 x 19 mm	0.50		
64-0907-05	Bolt 4 x 28 mm	0.50		
2-110	Lock Nut 4 mm	0.50		
64-0907-07	5 Player Rod 15.8 mm	16.00		
64-0907-08	2 Player Rod 15.8 mm	16.00		
64-0907-09	3 Player Rod 15.8 mm	16.00		
64-0907-10	Black Player 15.8 mm	2.50		
64-0907-11	Gray Player 15.8 mm	2.50		
64-0907-12	Bumper 15.8 mm	1.00		
64-0907-13	Plastic Washer 15.8 x 38 mm	0.50		
64-0907-14	Rod End Cap 15.8 mm	0.50		
64-0907-15	Plastic Handle	5.00		
64-0907-16	Slide Scorer	5.00		
3-163	Flat Countersunk Screw 4 x 18 mm	0.50		
64-0907-18	Soccer Ball	1.00		
64-0907-19	Wrench	1.00		

Subtotal	
S/H	
Tax	
Total	

Shipping will be added. If paid by Check or Money Order, call for quote.
 5.1% Waukesha Wisconsin tax will apply (subject to change).

Method of Payment

Check or Money Order
 Credit Card
 Visa MasterCard Discover American Express
 Card # _____
 Security Code # _____ Billing Address Zipcode _____
 Signature _____ Exp. Date _____

Shipping Address

Name _____
 Address _____ Phone _____
 City _____ State _____ Zip _____

GLD[®]

P R O D U C T S

www.gldproducts.com

GAME TABLES

HOME CASINO

GAMES AND ACCESSORIES

BILLIARD CUES

BILLIARD ACCESSORIES

DARTBOARDS

SOFT-TIP DARTS

STEEL-TIP DARTS

FLIGHTS AND SHAFTS

DART CASES AND ACCESSORIES



PROUD MANUFACTURER OF



S84 W19093 Enterprise Drive • Muskego, WI 53150 USA
262.679.8730 or 1.800.225.7593 tele
262.679.8738 or 1.800.841.6944 fax
262.679.8739 international fax
Email: gld@gldmfg.com
www.gldproducts.com