



FRISCO 7' Pool Table

Item 64-0131-07

FRISCO POOL TABLE

7 Foot Table

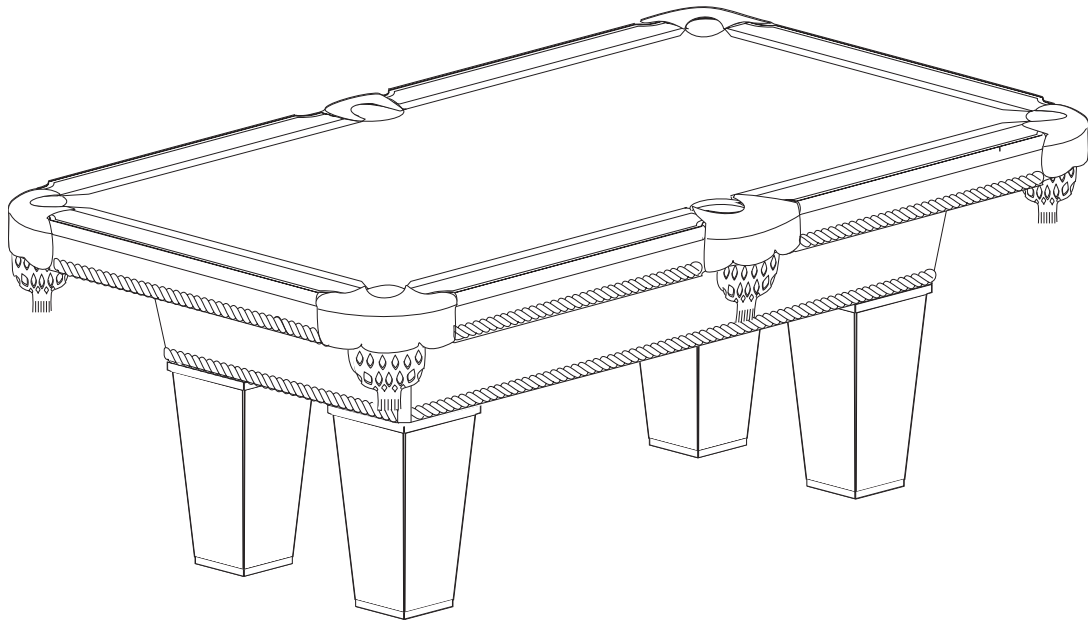

Replacement Parts

Order direct at www.gldproducts.com
or call our Customer Service department at

(800) 225-7593

8 am to 5 pm Central Standard Time

Staple your receipt here.

Important: A copy of your receipt will be needed to activate your warranty (see page page 14)

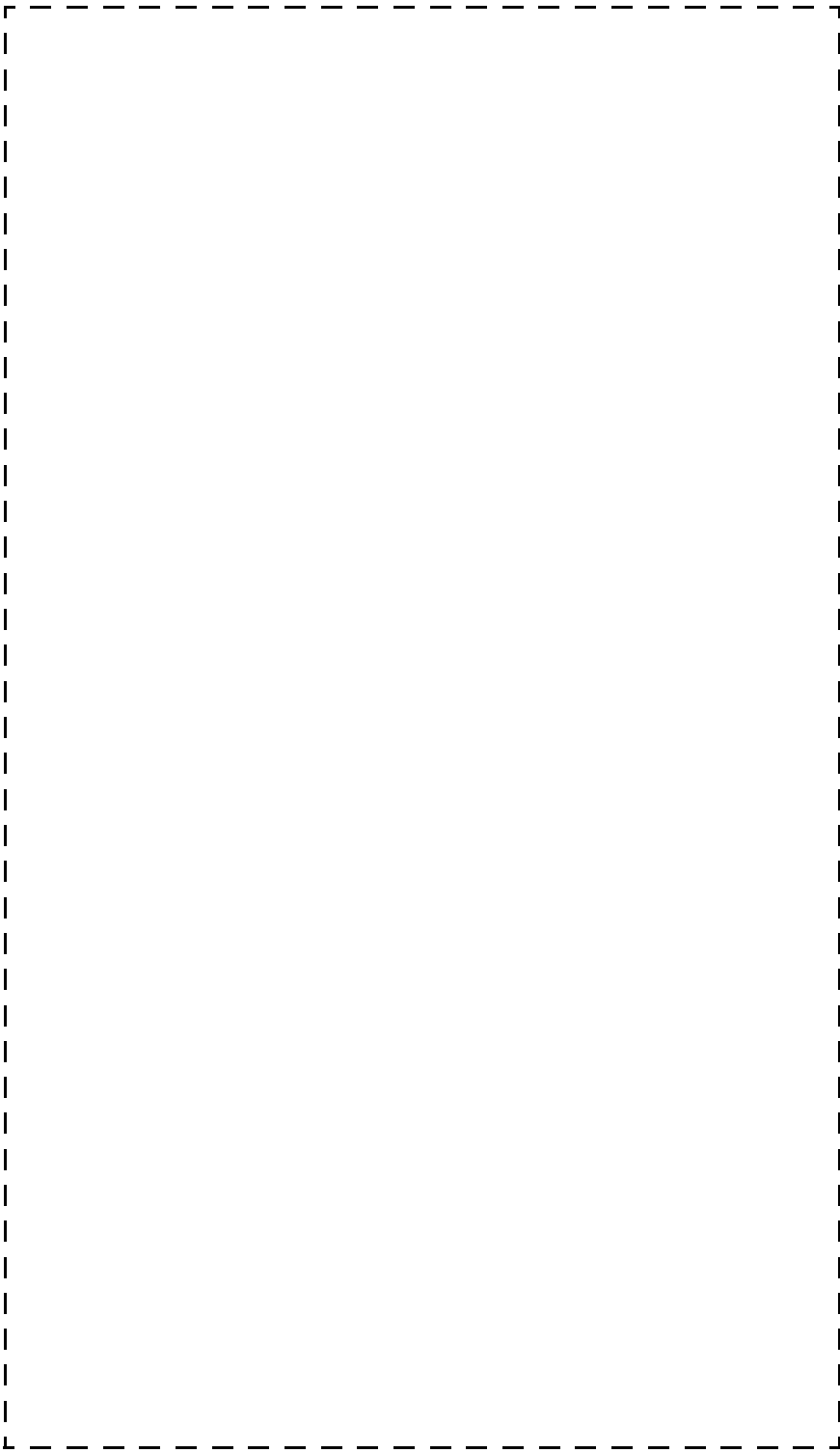



Congratulations and THANK YOU for purchasing the FRISCO Pool Table. You have chosen a product that should provide years of entertainment. To assist you with customer service and warranty claims, staple your receipt to the inside cover, then keep this manual in a safe place for future reference.

GLD Products

S84 W19093 Enterprise Drive
Muskego, WI 53150 USA
1-800-225-7593
Fax: 1-800-841-6944
Email: gld@gldmfg.com
Web: www.gldproducts.com











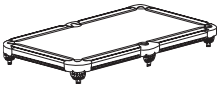

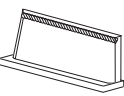
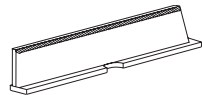
This manual may have been updated. For the latest manual visit GLD Products website.

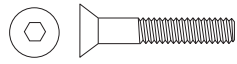
	<p>Place your package near the location where it will be used. Carefully unpack all components and verify you have all the correct pieces.</p> <p>If you notice missing or defective parts, please call us at: 1-800-225-7593.</p>
-------------------------------------------------------------------------------------	-----------------------------------------------------------------------------------------------------------------------------------------------------------------------------------------------------------------------------------------------

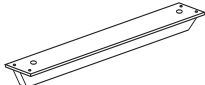
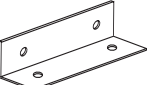
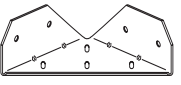
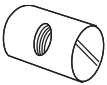
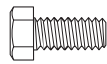
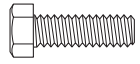
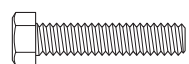
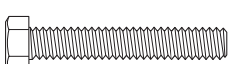
	<p>Please read and understand all instructions before beginning assembly.</p> <p>This assembly will require 2 adults.</p> <p>This product is not for use by children without adult supervision.</p>
-------------------------------------------------------------------------------------	------------------------------------------------------------------------------------------------------------------------------------------------------------------------------------------------------------

This pool table does not include pool balls, cue sticks, ball rack, chalk, or table brush.

Parts Identifier

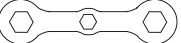
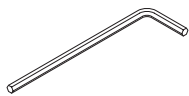
Part No./ Qty	Illustration/ Order Number	Part No./ Qty	Illustration/ Order Number	Part No./ Qty	Illustration/ Order Number
1 Qty. 1	 Table Top Assembly Order No. 1-28	2 Qty. 16	 Table Leg Side Order No. 1-31	3 Qty. 2	 End Cabinet Apron Order No. 1-30
4 Qty. 2	 Side Cabinet Apron Order No. 1-29	5 Qty. 4	 Leg Top Order No. 1-33	6 Qty. 4	 Leg Bottom Order No. 1-34
7 Qty. 32	 1/4 x 1-1/8" Socket Head Allen Screw Order No. 1-24	8 Qty. 32	 2" Phillips Head Screw Order No. 1-25	9 Qty. 32	 1/4 x 15 mm Flat Washer Order No. 1-26
10 Qty. 2	 Support Beam Order No. 1-5	11 Qty. 4	 Angle Bracket Order No. 1-6	12 Qty. 4	 Leg Mounting Bracket Order No. 1-7
13 Qty. 4	 5/16-18 Barrel Nut Order No. 1-8	14 Qty. 32	 5/16-18 x 3/4" Hex Head Bolt ^a Order No. 1-9	15 Qty. 16	 5/16-18 x 1-1/8" Hex Head Bolt ^a Order No. 1-10
16 Qty. 18	 5/16-18 x 2" Hex Head Bolt ^a Order No. 1-11	17 Qty. 4	 5/16-18 x 5 1/2" Hex Head Bolt ^a Order No. 1-12	18 Qty. 4	 5/16 x 15 mm Flat Washer Order No. 1-13
19 Qty. 48	 5/16 x 23 mm Flat Washer Order No. 1-14	20 Qty. 18	 5/16 x 32 mm Flat Washer Order No. 1-15	21 Qty. 4	 Leveler Order No. 1-27
22 Qty. 8	 1-1/2" Phillips Head Screw Order No. 1-32	23 Qty. 1	 Wrench Order No. 1-17	24 Qty. 1	 Allen Wrench 5/32" Hexagonal Order No. 1-16

a. If replacement bolts are needed a 7/16" Hex Head Bolt can be used.

Common fasteners are available at your local hardware store.

IF YOU HAVE A WARRANTY CLAIM, CALL US FIRST:

Please refer to page 14.

GLD Products

Available 8 am to 5 pm Central Standard Time

S84 W19093 Enterprise Drive

Muskego, WI 53150 USA

1-800-225-7593

Fax: 1-800-841-6944

Email: gld@gldmfg.com

Web: www.gldproducts.com

For all claims, please have your receipt and item number when you call. The product item number can be found on the front cover.

If you are instructed to return the product for service, you are responsible for shipping the unit at your expense.

PRODUCT REGISTRATION

Important: The product registration form on page 15 and a copy of your receipt must be completed and returned within 10 days of purchase to validate your warranty.

Preparing for Assembly

- Be sure to unpack all of the parts included in this package. Some parts may be in obscure locations of the packaging. Check inside any tubes or sleeves. Save all packing material until the product is fully assembled and functional.
- Compare the parts in your package with the Parts Identifier description on page 4.
- After unpacking large products, some disassembly may be required prior to beginning the assembly.

Tools Required

- Wrench (#23) included with table.
- 5/32" Allen wrench (#24) - included with table
- Phillips screwdriver (not included)
- Flat head screwdriver (not included)
- Level (not included)
- Electric screwdriver may be helpful. **CAUTION:** You must set at LOW TORQUE and use extreme caution because you could overtighten the hardware, strip the screws or damage the table.
- 12 mm Hex socket or wrench (not included)

Assembly Tips

Make sure you understand the following before you begin to assemble your game table.

1. READ THIS MANUAL all the way through before beginning assembly.
2. When installing parts that have more than one bolt, start ALL bolts in that part by hand before tightening anything.
3. Some drawings or images in this manual may not look exactly like your product.
4. You will need a second adult to assist with this assembly.

Note: Save all packing materials until the parts have been inspected and the table is assembled.

Unpack the Pieces

- Lay the box on a flat surface (floor). You may want this near your area of assembly.
- Several boxes should be visible and strapped to the underside of the table top.
- The table top should be at the bottom.
- The straps should be removed and the boxes opened. Some table designs require that the legs be shipped separately.
- Unpack the boxes and part bags. Inspect and count the parts. The Parts Identifier page can be used to record your results.
- If any parts are damaged or missing contact GLD customer service.
- Missing fasteners may be purchased at a hardware store using the descriptions on the Parts Identifier page(s).

STEP 1 - ASSEMBLE THE APRONS

1. Place the four apron side pieces (#3 and #4) in position. They should be upside down.
2. Use an angle bracket (#11) in each corner. Finger start four bolts (#14) with washers (#19) through the angle bracket and into two of the apron pieces.
3. Repeat in all four corners.
4. Tighten all the bolts (wrench #23). When tightening the bolts, be certain the two pieces are properly lined up at the corners.

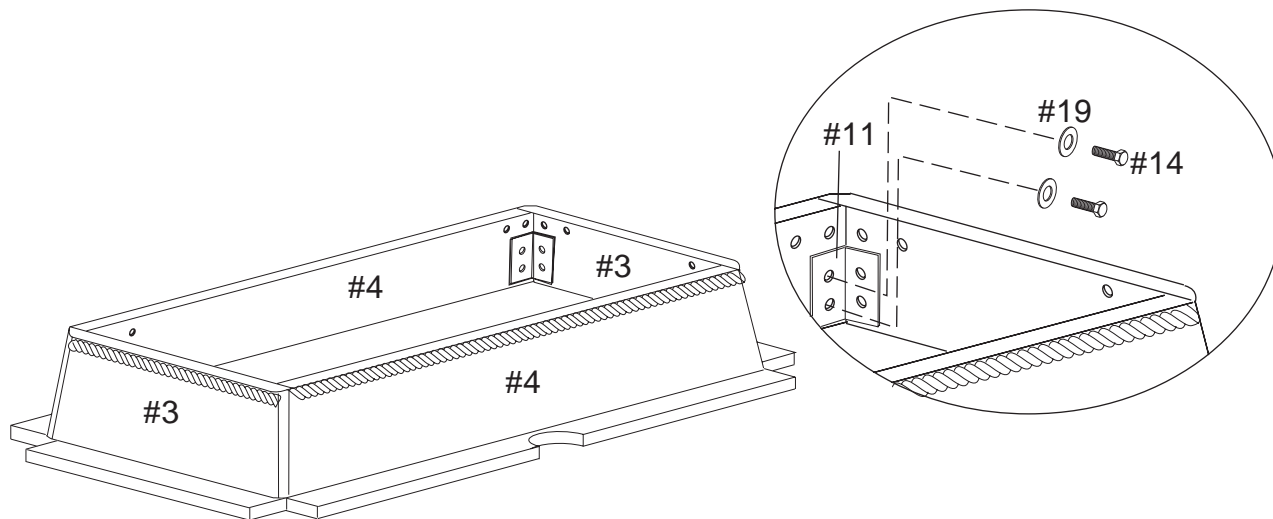

STEP 2 - ASSEMBLE LEG BRACKET

1. Install one leg mounting bracket (#12) in each corner. Use four bolts (#14) with washers (#19). Finger start all the bolts. Note that the flat part of the bracket will be up and even with the side aprons.
2. Hold the bracket in position and tighten all the bolts (wrench #23).

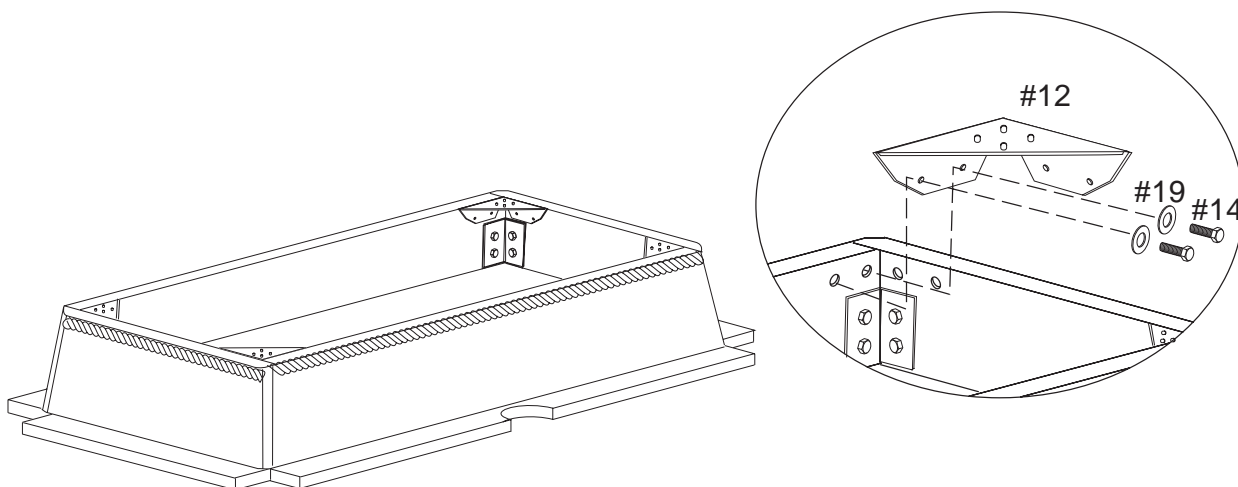

STEP 3 - ASSEMBLE THE LEGS

All of the leg sides are the same and can be assembled interchangeably.

1. Select two leg sides (#2) and position them as shown.
2. Start two screws (#7) with washers (#9) then tighten with Allen wrench (#24). Repeat with remaining sides to form 4 legs.
3. Prepare the leg tops (#5) by starting the 4 screws (#8) from the finished side of the top piece. To make assembly easier, a small length of the screw tips should be protruding out on the rough side of the leg top.
4. Position the top piece with the screw points in the predrilled holes in the top of the leg assemblies.
5. Start each screw into the leg. Tighten all 4 screws in each leg using a Phillips screwdriver and turn the legs over.
6. Prepare the 4 leg bottoms (#6) by starting the 4 screws (#8) from the finished side of the leg bottom. To make assembly easier, a small length of the screw tips should be protruding out on the rough side of the leg bottom.
7. Position the bottom piece with the screw points in the predrilled holes in the leg sides.
8. Start each screw into the leg. Tighten all 4 screws using a Phillips screwdriver.
9. Repeat for the remaining legs.

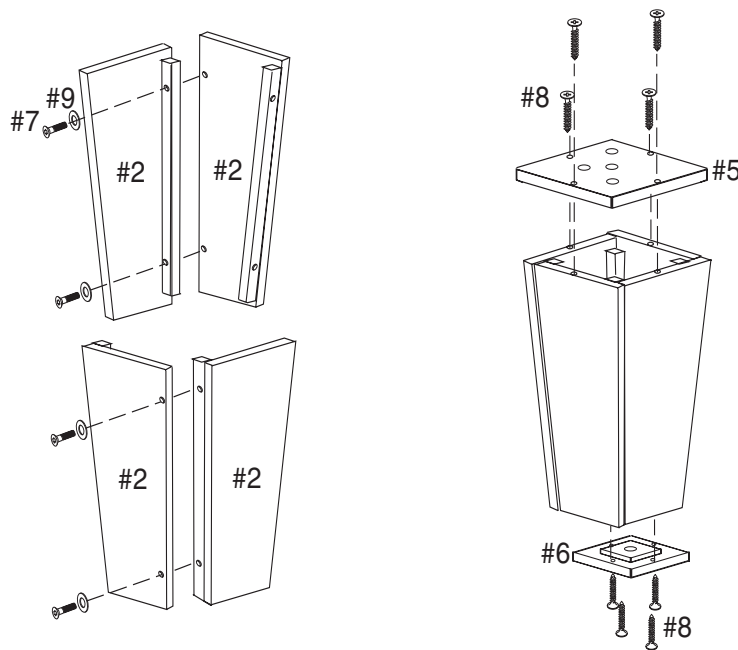

STEP 4 - ATTACH THE LEGS

1. Each leg is held in place by four bolts (#15) with washers (#19).
2. Position the leg on top of the bracket. Insert a bolt with washer through the bracket and into the leg.
3. Finger start all four bolts, then hold the leg in its final position.
4. Tighten the bolts using the wrench (#23). Repeat for the other 3 legs.
5. Screw the leveler (#21) half-way into the bottom of each leg.

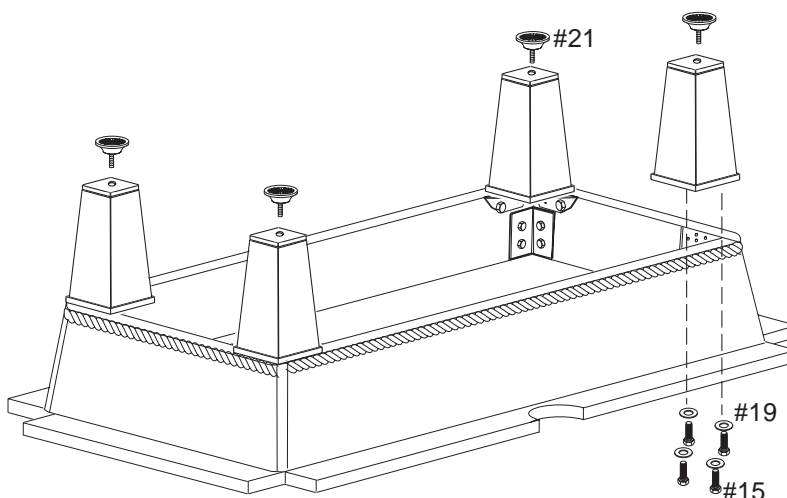

STEP 5 - TURN BASE OVER

The base assembly is ready to be turned over.

USE AT LEAST TWO PEOPLE TO LIFT THE BASE ASSEMBLY AND TURN IT OVER TO REST ON THE LEGS.

DO NOT ROLL THE TABLE OVER. This will place a sideways force on the legs. The legs should be off the floor until the base assembly is rotated completely. Set the base assembly down.

If visually the leg positions need adjusting, loosen the bolts, adjust, and retighten.

DO THIS

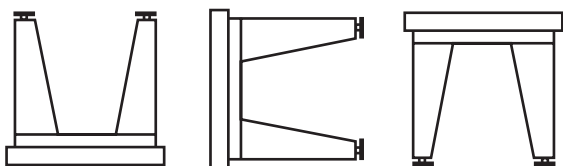

NOT THIS

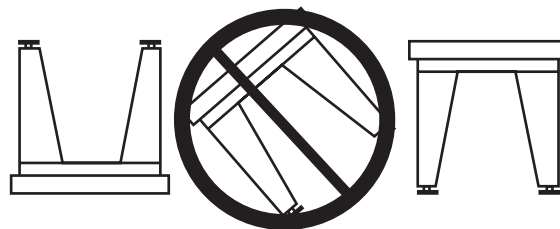

STEP 6 - INSTALL SUPPORT BEAMS

1. The table base is now right-side up. To install the two support beams (#10), position the support beams on the base assembly in the appropriate slots.
2. Insert a bolt (#17) with a washer (#18) through the side support.
3. Insert a barrel nut (#13) into the hole at the end of the beam, making sure the slot is visible and the slot lines up with the bolt. Thread the bolt into the barrel nut. If the barrel nut drops too far into the hole in the support beam, the threads will not engage. If this happens, use a magnet or turn the support beam over to remove the barrel nut. Thread the bolt into the barrel nut.
4. Hold the support beam in place by screwing in the side support bolt until snug, not tight.
5. Insert two screws (#22) in the ends of the support beams and tighten using a Phillips screwdriver.
6. Tighten the bolts using a 12 mm socket wrench.

NOTE: The support beams should not rise up above the surrounding frame. If this happens loosen the bolt until the support drops. The bolt can be tightened after the top is on and secure.

7. The base can now be leveled.

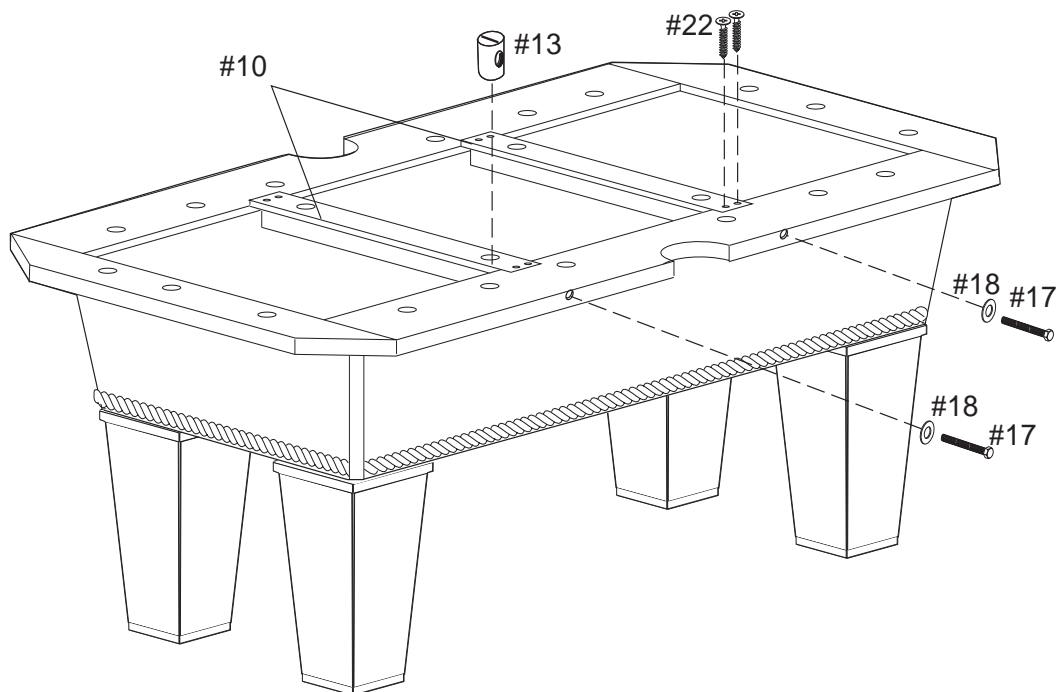

STEP 7 - LEVEL THE TABLE BASE

1. Put the base where you will be using the table.
2. Use a carpenters level to find the low side.
3. Lift the table leg off the floor and unscrew the leveler in the bottom of the leg a small amount.
4. Repeat until the base is level. Be sure to check level at both ends side to side as well as the longer length.

STEP 8 - ATTACH THE TABLE TOP

1. Using at least two people, lower the table top (#1) onto the base.
2. Line up one or two of the holes in the top with the holes in one end of the base assembly.
3. Finger start a bolt (#16) with a washer (#20) into the hole(s).
4. Line up the remaining holes and finger start a bolt with a washer in each.
5. Check the position of the table top, then tighten all the bolts.

CAUTION: If using a power tool to tighten the bolts, be certain it is on a low torque setting.

6. If the two support beams need to be tightened do it now. Tighten the four bolts until snug. Over-tightening will lift the table top upward.

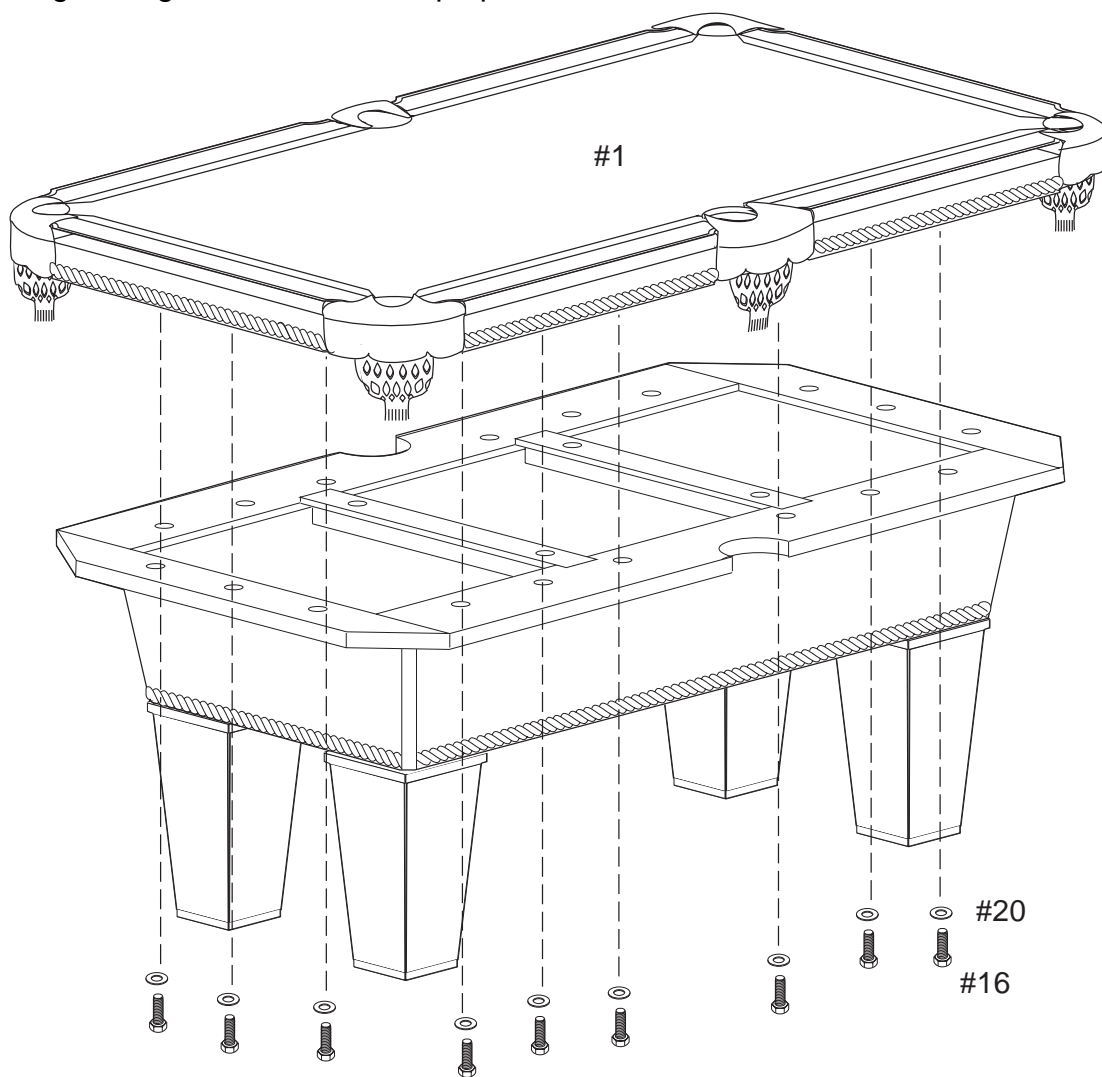

THE TABLE IS ASSEMBLED. IF IT IS NOT ALREADY IN POSITION FOR PLAY, IT CAN BE MOVED.

DO NOT SLIDE OR DRAG. Use at least two adults to lift into position, then re-level.

Care and Use of your Table

- This product is intended for INDOOR use only.
- DO NOT sit, climb, or lean on the table.
- DO NOT drag the table when moving it. This will damage the legs.
- Keep your table covered. The playing surface can be brushed or lightly vacuumed with low suction.
- DO NOT lift the table by placing your hands under the pockets, and do not sit, lean or put pressure on the pockets.
- The cloth playing surface can rip or tear. Keep sharp objects off the playing surface.
- Some "trick shots" may tear or dimple the cloth surface.
- To clean the hard surfaces spray a cloth with a mild cleaner and wipe.

90-DAY LIMITED WARRANTY

The Manufacturer warrants to the original retail purchaser that this product is free from defects in material and workmanship under normal use and conditions for a period of ninety (90) days from the date of original purchase. Further, the Manufacturer warrants to the original retail purchaser that the Accu Slate playing surface of your game table will remain flat, within a tolerance of +/- 30/1000 of an inch, measuring from any flat plane within the Accu Slate playing surface for a period of seven (7) years from the date of original purchase. The Manufacturer's liability is limited to the repair or replacement, at its option, of any defective product and shall not include any liability for indirect, incidental or consequential damages of any kind.

Should this product become defective due to material or workmanship within the warranty period, contact our Customer Service Department. This warranty is not transferable and does not cover normal wear and tear or damage caused by improper usage, negligence, misuse, abuse, transportation damage, acts of nature, or accident (including failure to follow the instructions in this manual). It does not cover expendable items such as batteries, light bulbs, fuses, accessories, cosmetic parts and other items that wear out due to normal usage, including felt covered areas of the playing surface. This warranty is also void if the product is disassembled and reassembled, damaged, modified from its original state, or used for other than indoor personal residential use (no commercial or rental applications).

This warranty gives you specific legal rights, and you may have other rights which vary from state to state.

IF YOU HAVE A WARRANTY CLAIM, CALL US FIRST (8 - 5 CST):

Please have your receipt and item number (found on the front cover) when you call.

GLD Products

S84 W19093 Enterprise Drive
Muskego, WI 53150 USA
1-800-225-7593
Fax: 1-800-841-6944
Email: gld@gldmfg.com
Web: www.gldproducts.com

If you are instructed to return the product for service, you are responsible for shipping the unit at your expense to the above address in packaging that will protect against further damage. All warranty or repair requests require a Return Authorization Number prior to returning the item.

PRODUCT REGISTRATION

Important: The product registration form on page 15 must be completed and returned along with a copy of your receipt within 10 days of purchase to validate your warranty.

REGISTER YOUR PRODUCT

Place postage here

Complete this form, include a copy of your receipt, fold, tape (do not staple) and return within 10 days of purchase. This protects your warranty and will help us develop new products!

Cut here.

GLD Products
 Warranty Department
 S84 W19093 Enterprise Drive
 Muskego, WI 53150 USA

Fold here second.



www.gldproducts.com

- | | |
|-----------------------|----------------------------|
| GAME TABLES | HOME CASINO |
| GAMES AND ACCESSORIES | BILLIARD CUES |
| BILLIARD ACCESSORIES | DARTBOARDS |
| SOFT-TIP DARTS | STEEL-TIP DARTS |
| FLIGHTS AND SHAFTS | DART CASES AND ACCESSORIES |

Fold here first.

Name		Date of Purchase
Address		Phone-Day
City		Phone-Evening
State	Zip	Email
Purchase Price:		Item: 64-0131-07 FRISCO 7' Pool Table
Store Name:		

1. What are the top two reasons that influenced the purchase of this product? Select two.

- | | | | |
|--------------------------|-------------------------|--------------------------|-------------------------------------------|
| <input type="checkbox"/> | Brand reputation | <input type="checkbox"/> | Prior experience with another GLD product |
| <input type="checkbox"/> | Saw in an advertisement | <input type="checkbox"/> | Color/appearance |
| <input type="checkbox"/> | Quality/durability | <input type="checkbox"/> | Other |
| <input type="checkbox"/> | Value for price | | |

2. How did you become aware of this product? Select two.

<input type="checkbox"/>	Saw in an advertisement	<input type="checkbox"/>	Saw it in the store
<input type="checkbox"/>	Saw or used a friend's or relative's	<input type="checkbox"/>	Recommended by another person
<input type="checkbox"/>	Received as a gift	<input type="checkbox"/>	Other

3. Rate your satisfaction with each of the following?

	Excellent	Good	Fair	Poor
Assembly instructions				
Ease of assembly				
Packaging				
Overall product satisfaction				

4. Were there any parts missing?

Yes No If so, which ones? Order No. _____

5. Based on your experience, would you buy another GLD product?

Yes No

6. Is this the first GLD product that you've owned? If No, what other product have you owned?:

Yes No _____

7. Have you owned products from:

Sportcraft Harvard Classic Sport Other

8. When did you decide to purchase this product?

Before entering the store. While in the store/impulse purchase

9. How many times per month will you use it?

1 to 3 4 to 8 9 to 15 16 +

10. Are you the intended user of this product?

Yes No, indicate who: _____

11. Where will you use this product?

Home Other: _____

12. Please tell us your gender?

Male Female

13. And your marital status?

Married Single

14. Age?

Under 25 25 - 40 40 - 60 Over 60

15. Which best describes your family income?

<input type="checkbox"/>	Under \$25,000	<input type="checkbox"/>	\$25,000 - \$49,999	<input type="checkbox"/>	\$50,000 - \$99,999
<input type="checkbox"/>	\$100,000 - 149,999	<input type="checkbox"/>	\$150,000 - \$199,999	<input type="checkbox"/>	Over \$200,000

16. Education:

<input type="checkbox"/>	Some high school	<input type="checkbox"/>	College degree
<input type="checkbox"/>	Completed high school	<input type="checkbox"/>	Graduate degree

Remember to attach a copy of your receipt.

Mail To: GLD Products
 S84 W19093 Enterprise Drive
 Muskego, WI 53150 USA
 1-800-225-7593 • FAX 800-841-6944
 Email: gld@gldmfg.com
 Web Site: www.gldproducts.com

FRISCO 7' Pool Table

Item 64-0131-07

Parts Re-Order Form

Name		Date
Address		Phone-Day
City		Phone-Evening
State	Zip	Email

Order No.	Description	Unit Price	Qty.	Total Amount
1-28	Table Top Assembly	100.00		
1-31	Table Leg - 1 side	5.00		
1-30	End Cabinet Apron	15.00		
1-29	Side Cabinet Apron	20.00		
1-5	Support Beam	10.00		
1-6	Angle Bracket	5.00		
1-7	Leg Mounting Bracket	5.00		
1-8	5/16-18 Barrel Nut	1.00		
1-9	5/16-18 x 3/4" Hex Head Bolt	1.00		
1-10	5/16-18 x 1-1/8" Hex Head Bolt	1.00		
1-11	5/16-18 x 2" Hex Head Bolt	1.00		
1-12	5/16-18 x 5-1/2" Hex Head Bolt	1.00		
1-13	5/16 x 15 mm Flat Washer	1.00		
1-14	5/16 x 23 mm Flat Washer	1.00		
1-15	5/16 x 32 mm Flat Washer	1.00		
1-16	Allen Wrench	2.00		
1-17	Wrench	1.00		
1-33	Leg Top	3.00		
1-34	Leg Bottom	3.00		
1-24	1/4 x 1-1/8 Socket Head Allen Bolt	1.00		
1-25	2" Phillips Head Screw	1.00		
1-26	1/4" x 15 mm Flat Washer	1.00		
1-27	Leg Levelers	5.00		
1-32	1-1/2" Phillips Head Screw	1.00		

Subtotal	
S/H	
Tax	
Total	

Shipping will be added. If paid by Check or Money Order, call for quote.
 5.1% Waukesha Wisconsin tax will apply (subject to change).

Method of Payment

_____ Check or Money Order
 _____ Credit Card
 _____ Visa _____ MasterCard _____ Discover _____ American Express
 Card # _____
 Security Code # _____ Billing Address Zipcode _____
 Signature _____ Exp. Date _____

Shipping Address

Name _____
 Address _____ Phone _____
 City _____ State _____ Zip _____



www.gldproducts.com

GAME TABLES

HOME CASINO

GAMES AND ACCESSORIES

BILLIARD CUES

BILLIARD ACCESSORIES

DARTBOARDS

SOFT-TIP DARTS

STEEL-TIP DARTS

FLIGHTS AND SHAFTS

DART CASES AND ACCESSORIES



PROUD MANUFACTURER OF



S84 W19093 Enterprise Drive • Muskego, WI 53150 USA
262.679.8730 or 1.800.225.7593 tele
262.679.8738 or 1.800.841.6944 fax
262.679.8739 international fax
Email: gld@gldmfg.com
www.gldproducts.com