

X-TREME ELECTRONIC DARTBOARD



Replacement Parts

Order direct at www.gldproducts.com
or call our Customer Service department at
(800) 225-7593
8 am to 4:30 pm Central Standard Time

Staple your receipt here.

Important: A copy of your receipt will be needed to activate your warranty (see page 34).

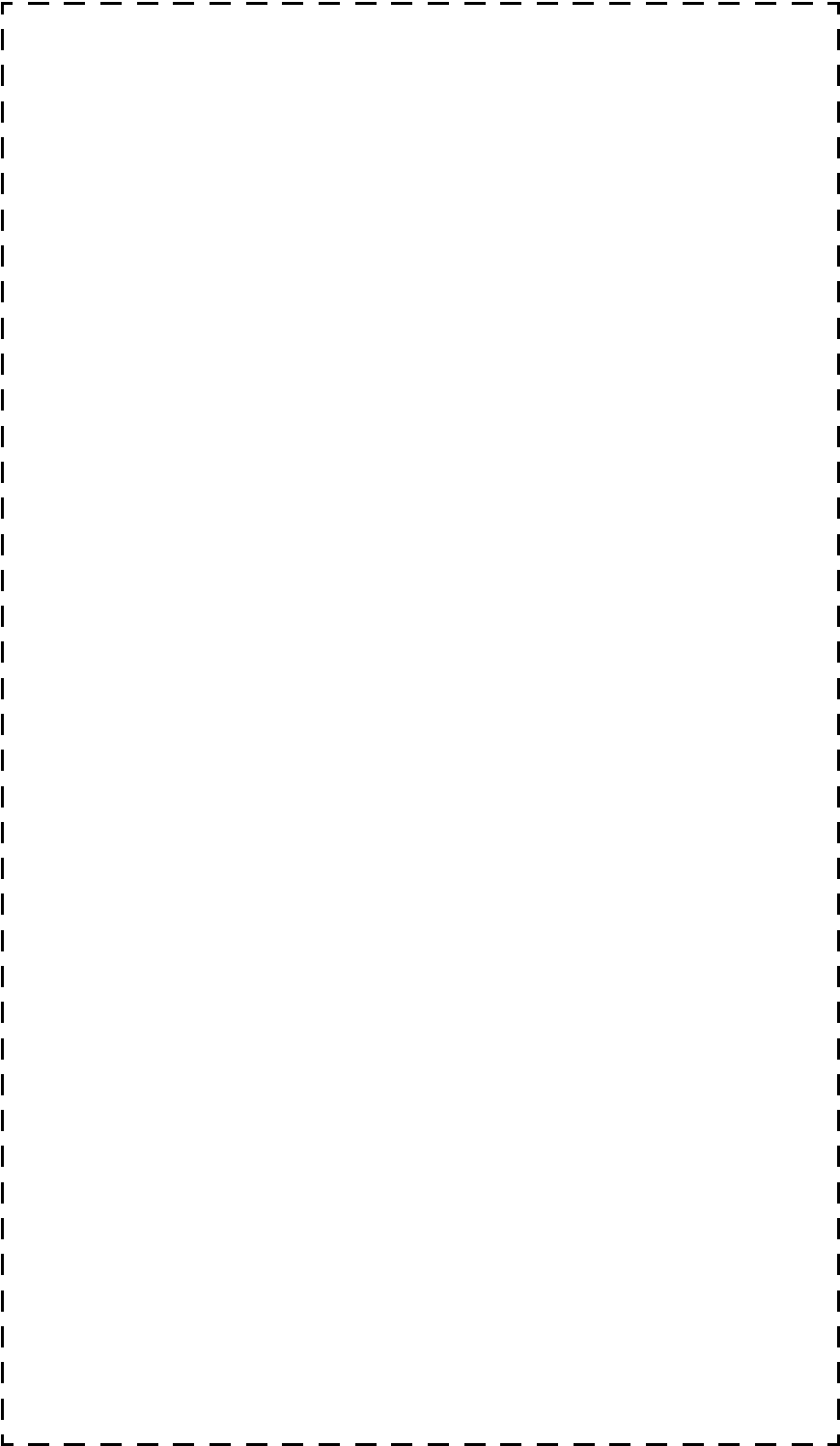

Congratulations and THANK YOU for purchasing the X-treme Dartboard. You have chosen a product that should provide years of entertainment. To assist you with customer service and warranty claims, staple your receipt to the inside cover, then keep this manual in a safe place for future reference.

GLD Products

S84 W19093 Enterprise Drive
Muskego, WI 53150 USA
1-800-225-7593 ext 113
Fax: 1-800-841-6944
Email: gld@gldmfg.com
Web: www.gldproducts.com

This manual may have been updated. For the latest manual visit the GLD products website.

	<p>Place your package near the location where it will be used. Carefully unpack all components and verify you have all the correct pieces.</p> <p>If you notice missing or defective parts, please call us at: 1-800-225-7593 ext. 113</p>
---	---

	<p>Please read and understand all instructions before beginning assembly.</p> <p>This assembly will require 2 adults.</p>
---	--

	<p>Choking Hazard This game has small parts that may break free and present a choking hazard. Children should be supervised by an adult when playing this game.</p>
---	--

IF YOU HAVE A WARRANTY CLAIM, CALL US FIRST

Please see page 34.

GLD Products

Available 8 am to 4:30 pm Central Standard Time

S84 W19093 Enterprise Drive
Muskego, WI 53150 USA
1-800-225-7593 ext 113
Fax: 1-800-841-6944
Email: gld@gldmfg.com
Web: www.gldproducts.com

For all claims, please have your receipt and item number when you call. The product item number can be found on the front cover.

If you are instructed to return the product for service, you are responsible for shipping the unit at your expense.

PRODUCT REGISTRATION

Important: The product registration form on page 35 and a copy of your receipt must be completed and returned within 10 days of purchase to validate your warranty.



WARNING: Parents - Please read instructions carefully. Not for use by children without adult supervision.

Thank you for purchasing the GLD X-treme Dartboard. The computerized scoring system makes game playing easy and enjoyable. With 48 games and 266 options to choose from, beginners and more advanced players will find challenging games to suit them.

TOOLS REQUIRED

- Tape measure
- Nail or marker
- Phillips screwdriver
- Level
- Mounting hardware (provided)

UNPACKING THE GAME

After unpacking the game, it is important to save the original box, all packing material, and the receipt. These items will be needed if it ever proves necessary to return the game for service.

MOUNTING (PHYSICAL INSTALLATION)

Two methods for mounting the dartboard are available.

1. Use the three keyhole slots and mount the center of the dartboard following the illustration. The three screws are screwed into the wall until the screw head is 3/8" away from the wall. The dartboard is positioned so the two screw heads are inside the keyhole. Slide the dartboard down to secure. The head of the screw that is used must be larger than 5/16" and smaller than 3/8".
2. Four equally spaced holes are accessible from the front to drive in screws. With the dartboard held in place, four screws are driven in from the front, through the existing holes. Use 1/8" diameter screws. The head of the screw must fit inside the pocket.

Wall Anchors

A wall with studs is the most common type of wall to mount the dartboard.

1. Locate a stud and use wood screws or sheet metal type screws to secure the dartboard.
2. If a stud cannot be located or is not in the proper location, use an anchor that is suitable for the type of wall.

Some common anchors are:

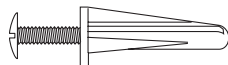

Plastic - Drill a snug hole in drywall and push the anchor in up to the head. When the screw is screwed into the anchor, the plastic will expand, locking the anchor in place. Do not use on thin panelling.

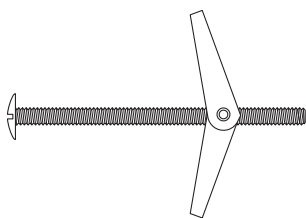

Toggle Bolt - Drill hole through wall. Hole must be large enough for the wings to pass through. Insert screw through the holes in the dartboard and thread the toggle wings just onto the screw. Fold the wings back and push through the hole until the wings spring open. Pull back on the screw to hold wings against the inside of the wall and tighten screw.

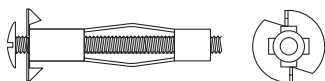

Hollow wall anchor - Drill a snug hole through the wall. Tap anchor into the hole until the prongs on the underside of the head are seated securely into the wall. Turn screw in and apply pressure to keep the anchor head from turning. Tighten screw until resistance is felt. Do not over tighten. Turn screw out to remove. Anchor will stay and screw can be replaced.

Other methods are available. Consult a hardware store if questions arise.

Mounting Using the Four Holes From the Front

1. Choose a location that is near an electrical outlet and has at least 10 feet of open floor space in front of the board. Use a wall stud for mounting whenever possible.
2. Two people are needed for this step. Hold board on the wall. Position center of bullseye 68" from the floor. Level the board. Hold in place.
3. Locate the four mounting holes on the front of the board. Use a marker or nail to mark the position of the board through the four mounting holes onto the wall. Remove the board.
4. Drill four pilot holes on the marks created in Step 3.
5. If using plastic anchors: drill the holes so the anchors fit snugly. Push anchors into place.
6. Line up dartboard over anchors. Screw board into place. The screws will expand the anchors.
7. Place a toe line 96" from the face of the board for the throwing distance. Adhesive tape or masking tape, 2' long by 2-1/2" wide, may be used.
8. After the board is mounted, the bullseye should be 68" (173 cm) above the floor.

Mounting Using the Keyhole Slots

1. Choose a location that is near an electrical outlet and has at least 10 feet of open floor space in front of the board. Use a wall stud for mounting whenever possible.
2. Determine the location for the dartboard. Place a mark on the wall 68 inches (172.7 cm) from the floor. This mark is the final position of the center of the dartboard (bullseye).
3. Locate studs and use wood screws or sheet metal screws to secure the dartboard if the mark is on the stud. The head of the screw must be larger than 5/16" and smaller than 3/8".
4. If the mark is not over a stud, use the mounting hardware that came with your dartboard.
5. Measure 8" (20.3 cm) directly up from the bullseye mark and place a mark on the wall. Then measure down 8" (20.3 cm) from the bullseye mark and place a mark on the wall. Use a level to check that all three marks are vertical.
6. Use the top mark and measure out level 8" (20.3 cm) to the left and right. Place a mark on the wall at both locations.
7. Drill pilot holes at the three marks. These are for the mounting screws.
8. If using wall anchors, follow the instructions under *Wall Anchors* on page 5.
9. Insert screws into anchors until a 1/4" (6.5 mm) gap is left between the wall and the screw head.

10. Hold the dartboard so the three screw heads fit into the lower part of the keyholes. The dartboard should slide down 1/2 inch and the screw heads will hold it on the wall.

11. Screws can be tightened or loosened to provide a secure mounting.

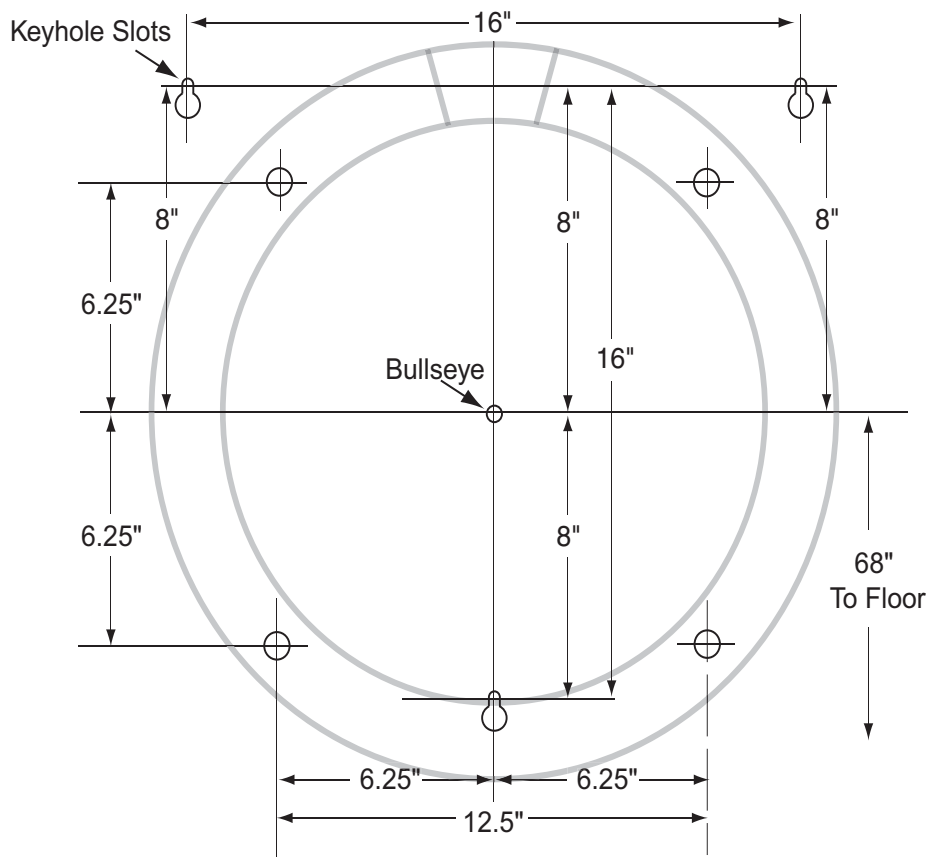
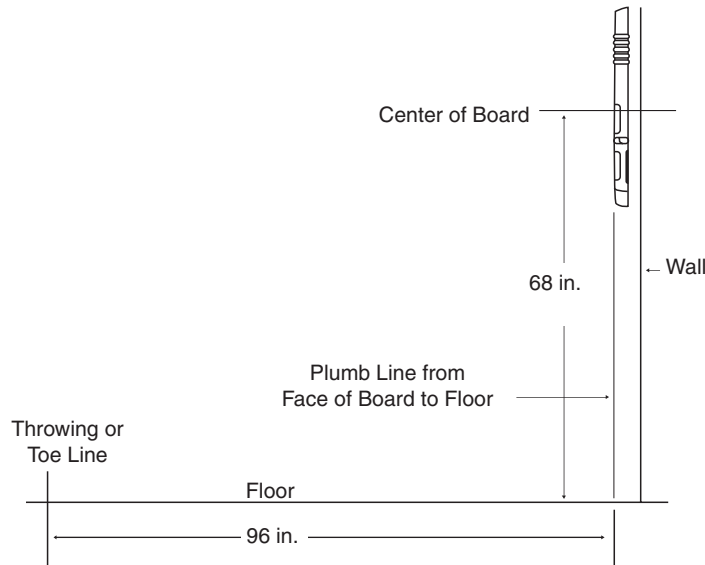

POWER INSTALLATION

The dartboard is designed to be powered by an AC to 9V DC, 500 milliamp (minimum) adapter, with the DC plug polarity configured as positive (+) outside, and negative (-) center. To connect the adapter, plug the DC plug into the DC power jack on the dartboard and the AC plug into an electrical outlet.

1. The board is not intended for children under the age of 3 years old.
2. The board must only be used with the recommended transformer.
3. The transformer is not a toy.
4. Disconnect the dartboard from the transformer before cleaning.

PROTECTIVE FILM

This electronic dartboard has a clear protective film over the entire display and button area to prevent scratching during shipping. It is recommended that you remove this film for easier reading of the display. To remove, simply lift edge, peel off and discard.



WARNING:

Not for use by children without adult supervision. Darts are not toys and may cause injury if used improperly. Everyone must stand behind the dart thrower.

IMPORTANT NOTES

1. During shipping or in the course of normal play, it is possible for scoring segments of this board to become temporarily jammed, resulting in a “frozen” board. If this occurs, the built-in **Self Diagnostic Function** of the e-BOARD Computer will be activated automatically. Your dartboard will run a self-test routine to determine which segment is stuck. An error message will flash on the display together with the number for the “Frozen” segment.

Error Code

Malfunction

99	Stuck ENTER Button
98	Stuck ELIMINATE Button
97	Stuck BOUNCE Button
96	Stuck ON/OFF Button
95	Stuck DOWN Button
94	Stuck UP Button
93	Stuck FAVORITE Button
92	Stuck AUTO CHANGE Button
91	Stuck SOUND Button
90	Stuck START/NEXT Button
Segment Number	A segment is stuck

Take the following steps immediately when the error message appears.

- a. Find the “frozen” segment according to the display.
- b. Press firmly down on the “frozen” segment until it breaks free and the loose fit is restored. Once the “frozen” segments are loosened, the error message should be gone and the board will continue to operate normally.
2. This game is designed for use with 3/4" length soft-tip darts only! Never use metal tipped darts or longer soft-tip darts on this dartboard! Metal tipped darts will seriously damage the circuitry, the e-BOARD computer, and electronic operation of the dartboard.
3. Electronic and mechanical reaction time is required between shots. If two shots occur too close together, pull out second dart and rethrow to properly record your score.
4. Use only the provided AC adapter. **Using the wrong adapter may cause electrical shock and damage to the unit.**
5. Do not use excessive force when throwing darts. Throwing a dart too hard will cause frequent tip breakage and cause excessive wear on the board.
6. Do not spill liquids on the dartboard. Do not use spray cleaners that contain ammonia or other harsh chemicals, as they may damage the dartboard. Instead, we suggest regular dusting with a damp cloth. Make sure the game is unplugged and use a mild detergent and a damp cloth for more vigorous cleaning.
7. This game is for indoor use only.

GAME OPERATIONS

<u>Segment Scoring</u>	<u>Scoring Rules</u>
Single scoring segment	score times 1
Double scoring segment	score times 2
Triple scoring segment	score times 3
Outer bullseye	25 times 1
Center bullseye	25 times 2

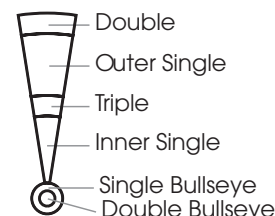

QUICK START - IF YOU JUST WANT TO START THROWING DARTS

1. Turn game on by pressing the ON/OFF button.
2. Press the UP button once.

NOTE: The scoreboard for player 1 will display G01 (Game 1 301). The scoreboard for player 2 will display 1P. The scoreboard for player 3 will display 301 (the default option).

3. Press the START/NEXT button to start the game.
4. Begin throwing darts. When your score reaches exactly 0 the game is over.

X-TREME GAME MENU

Game Number	Name	Options	Players
G01	301	8	1-16
G01	501	8	1-16
G01	601	8	1-16
G01	701	8	1-16
G01	801	8	1-16
G01	901	8	1-16
G02	301 League	8	4
G02	501 League	8	4
G02	601 League	8	4
G02	701 League	8	4
G02	801 League	8	4
G02	901 League	8	4
G03	Quick Cricket	5	1-16
G04	American Cricket	5	1-16
G05	Cut Throat Cricket	5	1-16
G06	Scram Cricket	1	2
G07	Double Only Cricket	3	1-16
G08	Random Cricket	1	1-16
G09	Shanghai	12	1-16
G10	Count Up 100	1	1-16
G10	Count Up 200	1	1-16
G10	Count Up 300	1	1-16
G10	Count Up 400	1	1-16
G10	Count Up 500	1	1-16
G10	Count Up 600	1	1-16
G10	Count Up 700	1	1-16
G10	Count Up 800	1	1-16
G10	Count Up 900	1	1-16
G11	Shoot Out	10	1-16
G12	Best of Nine	7	1-16
G13	Call Three	8	1-16
G14	Poker Darts	2	1-16

Game Number	Name	Options	Players
G15	Hound and Hare	5	2
G16	Halve-It	1	1-16
G17	Gold Hunting	5	1-16
G18	Killer	11	2-16
G19	Blind Killer	10	2-16
G20	Round-The-Clock	4	1-16
G21	Round-The-Clock Double/Triple	8	1-16
G22	Round-The-Clock The Irish Way	1	1-16
G23	Nine-Dart Century	3	1-16
G24	Baseball	3	1-16
G25	Football	1	1-16
G26	Bowling	6	1-16
G27	Golf	10	1-16
G28	Car Racing 1	1	1-16
G29	Car Racing 2	1	1-16
G30	Big Six	5	2-16
G31	Shove A Penny	1	1-16
G32	Hi Score	10	1-16
G33	Double Down	1	1-16
G34	Forty One	1	1-16
G35	Over	3	2-16
G36	Under	3	2-16
G37	All Fives	5	1-16
G38	Leg	3	2-16
Total		266	

READ FIRST - OPERATION

1. Plug the DC plug into the dartboard and the AC plug into a 110/120V electrical outlet.
2. Press the ON/OFF button to turn the game on. The dartboard will play a welcoming fanfare, and will display a greeting message "WELCOME TO GLD PRODUCTS E-BOARDS"
3. Use the UP and DOWN buttons to scroll through the menu of choices. Not all of the following choices may be available for every game. The screen will display the following:

SELECT GAME
SELECT OPTION
SELECT PLAYER
SELECT BULL
SELECT TEAMS
SELECT HANDICAP
CYBER PLAYER

4. Use the UP and DOWN buttons to scroll through the list of choices until the board displays and announces SELECT GAME. Push the ENTER button. Then use the UP and DOWN buttons to scroll through the list of games. The dartboard will announce and display the names of the different games. The game number will display in the Player 1 score display. Push the ENTER button to select the game you want to play.
5. The board will now display SELECT OPTION, press the ENTER button. Use the UP and DOWN buttons to scroll through your options. The option will display in the Player 3 score display. Press the enter button to select your option.
If you are playing Game **301** or **301 League** the board will now display SINGLE IN/SINGLE OUT. Use the UP and DOWN buttons to scroll through the choices. The Double In, Double Out and Master Out LED's on the score display will light when selected. Press the ENTER button to select your choice.

SINGLE IN/SINGLE OUT	Any segment in / Any segment out
SINGLE IN/DOUBLE OUT	Any segment in / Only double segments out
SINGLE IN/MASTER OUT	Any segment in / Only double or triple segments out
DOUBLE IN/DOUBLE OUT	Only double segments in/ Only double segments out
DOUBLE IN/MASTER OUT	Only double segments in/ Only double or triple segments out

6. The board will now display SELECT PLAYERS, press the ENTER button. Use the UP and DOWN buttons to scroll through your choices. Press ENTER to select your choice. You may not have a choice in the number of players for all games. The number of players you select will be displayed on the Player 2 score board.
7. If you are playing games **G01**, **G02**, **G03**, **G04** or **G05**, the board will now display SELECT BULL. Use the UP and DOWN buttons to alternate between DOUBLE BULL or SINGLE BULL. Press ENTER to select your choice.

DOUBLE BULL	Inner ring = 50 points and the outer ring = 25 points.
SINGLE BULL	Both rings = 50 points.

8. The board will now display SELECT TEAMS, press the ENTER button. Use the UP or DOWN buttons to scroll through your options. Press ENTER to select your choice. No team selection is available for games G02, G06, G15 and G19. The combination of the teams are as follows:

# of Players on Team	# of Teams	Team 1	Team 2	Team 3	Team 4
3	2	P1, P3	P2	—	—
	3	P1, P4	P2	P3	—
4	2	P1, P3	P2, P4	—	—
	3	P1, P4	P2	P3	—
	4	P1, P5	P2	P3	P4
5	2	P1, P3, P5	P2, P4	—	—
	3	P1, P4	P2, P5	P3	—
	4	P1, P5	P2	P3	P4
6	2	P1, P3, P5	P2, P4, P6	—	—
	3	P1, P4	P2, P5	P3, P6	—
	4	P1, P5	P2, P6	P3	P4
7	2	P1, P3, P5, P7	P2, P4, P6	—	—
	3	P1, P4, P7	P2, P5	P3, P6	—
	4	P1, P5	P2, P6	P3, P7	P4
8	2	P1, P3, P5, P7	P2, P4, P6, P8	—	—
	3	P1, P4, P7	P2, P5, P8	P3, P6	—
	4	P1, P5	P2, P6	P3, P7	P4, P8
9	2	P1, P3, P5, P7, P9	P2, P4, P6, P8	—	—
	3	P1, P4, P7	P2, P5, P8	P3, P6, P9	—
	4	P1, P5, P9	P2, P6	P3, P7	P4, P8
10	2	P1, P3, P5, P7, P9	P2, P4, P6, P8, P10	—	—
	3	P1, P4, P7, P10	P2, P5, P8	P3, P6, P9	—
	4	P1, P5, P9	P2, P6, P10	P3, P7	P4, P8
11	2	P1, P3, P5, P7, P9, P11	P2, P4, P6, P8, P10	—	—
	3	P1, P4, P7, P10	P2, P5, P8, P11	P3, P6, P9	—
	4	P1, P5, P9	P2, P6, P10	P3, P7, P11	P4, P8

# of Players on Team	# of Teams	Team 1	Team 2	Team 3	Team 4
12	2	P1, P3, P5, P7, P9, P11	P2, P4, P6, P8, P10, P12	—	—
	3	P1, P4, P7, P10	P2, P5, P8, P11	P3, P6, P9, P12	—
	4	P1, P5, P9	P2, P6, P10	P3, P7, P11	P4, P8, P12
13	2	P1, P3, P5, P7, P9, P11, P13	P2, P4, P6, P8, P10, P12	—	—
	3	P1, P4, P7, P10, P13	P2, P5, P8, P11	P3, P6, P9, P12	—
	4	P1, P5, P9, P13	P2, P6, P10	P3, P7, P11	P4, P8, P12
14	2	P1, P3, P5, P7, P9, P11, P13	P2, P4, P6, P8, P10, P12, P14	—	—
	3	P1, P4, P7, P10, P13	P2, P5, P8, P11, P14	P3, P6, P9, P12	—
	4	P1, P5, P9, P13	P2, P6, P10, P14	P3, P7, P11	P4, P8, P12
15	2	P1, P3, P5, P7, P9, P11, P13, P15	P2, P4, P6, P8, P10, P12, P14	—	—
	3	P1, P4, P7, P10, P13	P2, P5, P8, P11, P14	P3, P6, P9, P12, P15	—
	4	P1, P5, P9, P13	P2, P6, P10, P14	P3, P7, P11, P15	P4, P8, P12
16	2	P1, P3, P5, P7, P9, P11, P13, P15	P2, P4, P6, P8, P10, P12, P14, P16	—	—
	3	P1, P4, P7, P10, P13, P16	P2, P5, P8, P11, P14	P3, P6, P9, P12, P15	—
	4	P1, P5, P9, P13	P2, P6, P10, P14	P3, P7, P11, P15	P4, P8, P12, P16

9. The board will now display SELECT HANDICAP, if you would like to add a handicap for a player or a team, press ENTER. If you do not want to add a handicap press the UP button to scroll through to the next choice. Use the UP and DOWN buttons to scroll through the list of players or teams. Press ENTER to select a player or team that you want to give a handicap too. Use the UP and DOWN buttons to scroll through the list of handicap choices. Press the ENTER button to select the handicap you want. You can then add a handicap to another player. When you're done adding handicaps to all the players, use the UP or DOWN buttons to scroll through the list until it says EXIT. Press the ENTER button to exit.

10. The board will now display CYBER PLAYER, press ENTER if you would like to play with a cyber player. If you do not want to add a cyber player press the UP button to scroll through to the next choice or press the START/NEXT button to start the game. Use the UP and DOWN buttons to scroll through the choices for the level of difficulty for the cyber player. Press the ENTER button to select your choice. The cyber player will be the last player. The COMPUTER LED will light when a cyber player is selected. The choices for cyber player are as follows:

OFF CPU
BEGINNER
INTERMEDIATE
ADVANCED
EXPERT
PROFESSIONAL

11. You may now press the START/NEXT button to start your game. If you need to change one of your selections you may use the UP and DOWN buttons to scroll through the list again.
12. If a dart thrown at the board scores, but does not stick in the board, press the BOUNCE button. That particular score will be displayed at the Scrolling Text Display, then eliminate this score by pressing the ELIMINATE button.
13. After throwing three darts and if all of them hit the scoring segments, the dartboard will announce "NEXT PLAYER, REMOVE DARTS" and any pressure on the segments will not activate the computer. The player is required to take out all darts and press the START/NEXT button for the next player to continue the game.
14. Push the AUTO CHANGE button to select auto player change mode. The AUTO CHANGE LED will be lit when this mode is selected. When auto change mode is active (LED is lit) the board will change automatically after 10 seconds to the next player after a turn is over. If in manual mode (LED is not lit) you must push START/NEXT to move on to the next player.
15. When a player wins a game, the dartboard will announce "WINNER" and the celebration and applause will be heard. The dartboard will also display PLAYER X WINNER (the player number will be shown in the X space). For the 301 games the average points per dart for each player will display on their scoreboard. If playing more than one player the dartboard will then say "NEXT PLAYER". Push the START/NEXT button to move on to the next player.
16. After a game is completed the dartboard will flash GAME OVER and then PLAYER X RANK X. You can then use the START/NEXT button to scroll through the ranks of all the players.
17. If you hold down the ON/OFF button, the board will display CANCEL. You may then use the UP and DOWN buttons to scroll through a list of choices. Press ENTER to select a choice.

CANCEL	Will cancel what you are doing and take you back to what you were doing.
SHUT DOWN	Will turn the dartboard off.
RESET	Will return to the menu mode with the e-Board Computer system default settings.
QUIT	Will exit the game you are in and take you back to the main menu mode with previously confirmed game settings.

18. If no buttons or segments on the dartboard have been pushed for 5 minutes the dartboard will go into sleep mode. The dartboard will reactivate by pressing any button or segment and will return to where it was when it went into sleep mode. If the dartboard has been inactive for 15 minutes it will automatically shut down.

19. The SOUND button controls the volume level. If you push the SOUND button the screen will display the current sound setting. Keep pushing the SOUND button to go through the sound options until you find the one you want. To select your choice simply press another button or wait 2 seconds without pushing anything. The sound options are:

- SOUND OFF
- VOLUME LOW
- VOLUME MED
- VOLUME HIGH

20. The dartboard also has a FAVORITE button that allows you to store your 5 favorite games with your settings into memory. To store, first make the game's selections and other settings from the main menu. Then press the FAVORITE button followed by the WRITE button (also known as the DOWN button). The dartboard will then display STORE TO MEM 1. Use the UP and DOWN buttons to scroll through the list of locations to store the game to. Press ENTER to select your choice. The dartboard will then display STORED. If you attempt to save a game over one that is already saved the dartboard will display OVERWRITE MEM X. Press ENTER to overwrite or use the UP and DOWN buttons to select a different location. To recall a game setting from memory, press the FAVORITE button followed by the READ button (also known as the UP button). Then use the UP and DOWN arrows to find your choice. Press the ENTER button to make your selection. You may then press START/NEXT to start playing that game.

X-TREME GAME DESCRIPTIONS & RULES

G01 301 (with options of 301, 501, 601, 701, 801, 901 and Single In/Single Out, Double In/Single Out, Double In/Double Out, Single In/Double Out, Single In/Master Out, Double In/ Master Out and Double Bull, Single Bull)

Your options are the starting score for the game, see the chart below.

Option	301	501	601	701	801	901
Starting Score	301	501	601	701	801	901

The starting score for each player is 301 (or 501/601/701/801/901) as selected before starting the game. The score will be deducted for each dart that scores. The first player who reaches exactly zero (0) wins. You must go out with the exact number. If you go over zero the dartboard will announce "TOO HIGH, NEXT PLAYER, REMOVE DARTS".

For Single In or Single Out options, the game can be started or ended by throwing at any segment, regardless if single, double or triple. If you select Double In, you must hit a double segment or bullseye to start the game. If you select Double Out you must hit a double segment or bullseye to end the game. For Master Out, you must end with hitting a double or triple segments.

If Double Out has been selected, the Dart Out feature is automatically activated. In this mode, once a player is 170 or below, the e-BOARD Computer will suggest the 3 best possible finishing shots, or if an OUT is not possible, the best remaining alternative shots are displayed on the display at the top of the dartboard.

G02 301 League (with options 301, 501, 601, 701, 801, 901 and Single In/Single Out, Double In/Single Out, Double In/Double Out, Single In/Double Out, Single In/Master Out, Double In/ Master Out and Double Bull, Single Bull)

Your options are the starting score for the game, see the chart below.

Option	301	501	601	701	801	901
Starting Score	301	501	601	701	801	901

This game is played by 2 teams who compete with each other. Each team has 2 members. Team 1 is made up of player 1 and Player 3. Team 2 is made up of Player 2 and Player 4. Similar to 301, the team will win when one player's score reaches exactly zero (0), and his teammates score is lower than or equal to the sum of the score of the opposing team. Otherwise the score of the current player returns to the beginning of the turn. That team cannot win at that time.

Once a players score is below 181 for Single Out, or 171 for Double Out and their teammates score is lower than or equal to the the sum of the score of the opposing team, the dartboard will announce "GO FOR IT". This will confirm you have a chance to win in this round. If you have not met these conditions the dartboard will announce "FREEZE" even if their score comes to zero.





The same Single In/Out, Double In/Out and Master Out rules from game G01 301 apply.

G03 Quick Cricket (with options of C00, C20, C25 and Double Bull, Single Bull)

The options are described in the chart below.

Options	Description
C00	Hit and open numbers 15-20 and bullseye in any order.
C20	Hit and open the number 20 first, then in order, open numbers 19, 18, 17, 16, 15 and bullseye.
C25	Hit and open bullseye first, then in order, open numbers 15, 16, 17, 18, 19 and 20.

Following the standard rules, in Quick Cricket only the numbers 15-20 and bullseye are used. The first player to hit each number 3 times and open them all is the winner. If every player has opened a number, that number will then close. All valid hits will be confirmed and displayed by the Cricket Display.

Cricket Status	One Time	Two Times	Open	Close
Sign				

NOTE: A single segment counts as one hit, a double segment counts as two hits and a triple segment counts as three hits.

G04 American Cricket (with options of C00, C20, C25 and Double Bull, Single Bull)

The options are described in the chart below.

Options	Description
C00	Hit and open numbers 15-20 and bullseye in any order.
C20	Hit and open the number 20 first, then in order, open numbers 19, 18, 17, 16, 15 and bullseye.
C25	Hit and open bullseye first, then in order, open numbers 15, 16, 17, 18, 19 and 20.

Same as Quick Cricket, except more complicated scoring and winning procedures as follows:

- When a number has been hit 3 times by a player, it is then open to that player and any further hits by that player will score points.
- Once a number has been hit 3 times by all the players, that number is then closed and can no longer be scored upon by any player. At that time the indicator LED will change to closed for that number.
- A player who has opened a number can continue to score on that number until it becomes closed.
- A player wins the game when he first opens all the numbers and has an equal or greater score than the other players. However, if players are tied on points, or have no points, the first player to open all numbers wins.
- If a player has opened all numbers first, but is behind on points, scoring continues on open numbers. If that player has not accumulated the highest point total by the time another player opens all their numbers, the player with the most points will be the winner.

G05 Cut Throat Cricket (with options of C00, C20, C25 and Double Bull, Single Bull)

The options are described in the chart below.

Options	Description
C00	Hit and open numbers 15-20 and bullseye in any order.
C20	Hit and open the number 20 first, then in order, open numbers 19, 18, 17, 16, 15 and bullseye.
C25	Hit and open bullseye first, then in order, open numbers 15, 16, 17, 18, 19 and 20.

Same rules as Quick Cricket EXCEPT once the scoring begins, points are added to your opponents scores who haven't opened that number. The player who first opens all numbers and has the lower score wins.

G06 Scram Cricket

This game is a variation of Cricket. The game consists of 2 rounds. In the first round, player 1 must close 15 through 20 and bullseye while player 2 attempts to get as high a score as he can by scoring on the open numbers. Round 1 will be finished when all numbers have been closed. For round 2, the reverse is done. During round 2, if Player 1's score goes over Player 2's score the game will end and Player 1 will be the winner. If Player 2 closes all the numbers and has a higher score than Player 1, Player 2 will be the winner.

G07 Double Only Cricket (with options of C00, C20, C25)

The options are described in the chart below.

Options	Description
C00	Hit and open numbers 15-20 and bullseye in any order.
C20	Hit and open the number 20 first, then in order, open numbers 19, 18, 17, 16, 15 and bullseye.
C25	Hit and open bullseye first, then in order, open numbers 15, 16, 17, 18, 19 and 20.

This game is the same as American Cricket EXCEPT that you have to hit a double segment for each number first, in order for hits or scoring to be possible.

For example, to start with the number 20, you must hit the double 20 segment. Any hits before you do this will count as a miss. Once you've hit your double 20 you have three possibilities for that number:

- If you hit a single 20 it will open the 20 for scoring.
- If you hit a double 20 it will open the 20 for scoring and score you 20 points.
- If you hit a triple 20 it will open the 20 for scoring and score you 40 points.

Once all players have opened a number that number will close and no one can score on it anymore.

G08 Random Cricket

This game is the same as American Cricket EXCEPT that the e-Board Computer will randomly select numbers for you to hit. The first two digits on the display will show the player number (this will be a solid number, not flashing). The random numbers will flash on the display. Once a player hits one of the designated random numbers it will stop flashing and become solid. This number is now locked in for all players for the rest of the game. Numbers can be hit in any order. Once a players turn is over, the flashing numbers will change to a different set of random numbers. The numbers that are locked in (solid numbers) will stay the same.

You have to hit each designated number three times to open it. Double segments count as two hits and triple segments count as three hits. The first player to open all the numbers wins.

G09 Shanghai (with options of L01, L05, L10, L15, H01, H05, H10, H15, P01, P05, P10, P15)

The options are described in the chart below.

Option	L01	L05	L10	L15	H01	H05	H10	H15	P01	P05	P10	P15
Game starts on number	1	5	10	15	1	5	10	15	1	5	10	15
	Can hit any segment				Must hit double or triple segments				Various doubles and triples must be hit as specified by the computer			

Each player must hit numbers 1 through 20 and the bullseye in order. The dartboard will display the number you are supposed to hit. Throw 3 darts for each number and the player who gets the most points at the end of the game wins. Your score is the number of the segment you are on. Hitting a double segment in the number you are on will double your points, likewise a triple will triple your points. For example if you are on number 4 and you hit a single in segment 4 you get 4 points. If you are on number 4 and you hit a double segment 4 you get 8 points.

G10 Count Up (with options of 100, 200, 300, 400, 500, 600, 700, 800, 900)

The options are the set points which are the points needed to win, see the chart below.

Option	100	200	300	400	500	600	700	800	900
Set Points	100	200	300	400	500	600	700	800	900

Your score will be accumulated for each dart. The first player to reach or go over the set points will be the winner.

G11 Shoot Out (with options of -11, -12, -13, -14, -15, -16, -17, -18, -19, -20)

The options are the number of marks you must hit, see the chart below.

Option	-11	-12	-13	-14	-15	-16	-17	-18	-19	-20
No. of Marks	11	12	13	14	15	16	17	18	19	20

The e-BOARD Computer will randomly select a number for the player to hit. One correct hit scores one mark. If a player does not hit the selected number within 10 seconds, the dart is regarded as a miss and the e-BOARD Computer will automatically select another random number for the player to hit for the next dart. The first player who hits 11, 12, 13...20 marks, depending on the option selected, is the winner.

G12 Best of Nine (with options of 009, 012, 015, 018, 021, 024, 027)

The options are the number of darts thrown for the game, see the chart below.

Option	009	012	015	018	021	024	027
No. of Darts	9	12	15	18	21	24	27

The dartboard will announce “PLAYER 1” and display SELECT NO. Throw a dart to select your number. If you miss the dartboard you may continue to throw darts until you hit a number. The dartboard will then move on to the next player.

Once all players have selected their numbers, each player will then take turns throwing three darts. The object is to hit the number you selected. For every single segment hit in your number you will get one point. For every double segment hit in your number you will get two points and for every triple segment hit in your number you will get three points.

The cricket display will count down how many darts you have left. The player with the highest score at the end of the game wins.

NOTE: If all the players have the same score at the end of the game Player 1 will win. Player 2 will come in second, Player 3 third, and so on.

G13 Call Three (with options of R03, R04, R05, R06, R07, R08, R09, R10)

The options are the number of rounds played for the game, see the chart below.

Option	R03	R04	R05	R06	R07	R08	R09	R10
No. of Rounds	3	4	5	6	7	8	9	10

The e-Board Computer will select 3 random numbers. The player must hit the numbers in the order displayed. Hitting the number displayed in a single segment, is worth one point. If they hit the number displayed in a double segment they get two points and if they hit the number displayed in a triple segment they get three points. The cricket display will count down how many rounds you have left. The player with the highest score at the end of all the rounds wins.

G14 Poker Darts (with options of A00, D00)

The options for this game don’t change the way the game is played.

The game uses numbers 1-13 to play. These numbers represent a deck of cards. The e-Board Computer will assign 5 numbers to a player (5 cards in a hand of poker). The player must hit the double segment of any of their “cards” or numbers. When you do this it will eliminate that “card” or number for all players that have it. The cricket display will keep track of how many cards you have. The first player to get rid of all their “cards” or numbers wins.

G15 Hound and Hare (with options of 005, 012, 009, 014, 011)

The options are the number at which the Hound starts at, see the chart below.

Option	005	012	009	014	011
Number Hound Starts At	5	12	9	14	11

The “Hare” (Player 1) tries to escape from the “Hound” (Player 2) while the “Hound” tries to catch the “Hare”. The “Hare” (Player 1), starts at the double 20. The dartboard will display what number you must hit. Only the double segments are used in this game. The “Hare” (Player 1) must hit the double 20 to move clockwise to the next number. The “Hound” (Player 2) will start at the double 5 (or 12, 9, 14, 11) segment. The “Hound” (Player 2) must hit the double 5 (or 12, 9, 14, 11) segment to move clockwise to the next number. The players continue to take turns throwing darts and moving around the dartboard. The object is for the “Hound” to catch up to the “Hare”. If the “Hound” (Player 2) hits the same double number that the “Hare” (Player 1) is trying to hit, the “Hound” wins. If the “Hare” (Player 1) makes it back around the dartboard to the double 20, the “Hare” wins.

G16 Halve-It

There are seven rounds of three darts each in this game. Each round has a target number you must hit to score points. The dartboard will display the number you need to hit for that round. The target numbers for each round are:

Round	1	2	3	4	5	6	7
Target Number	20	16	Double 7	14	Triple 10	17	Bullseye

Players take turns throwing darts and attempting to score points. If you hit the target number for that round, you will get that number in points. Double segments will double your points and triple segments will triple your points. For example, in Round 1 you have to hit the number 20. If you hit it in a single segment you will get 20 points. If you hit the double 20 you will get 40 points and the triple 20 will give you 60 points. For Round 3 you can only score off the double 7 segment. For round 5 you can only score off the triple 10 segment and for Round 7 you can only score by hitting the bullseye. The outer bullseye ring is worth 25 points and the inner ring is worth 50. If a player misses the designated number on all three darts in a round, their total score is cut in half. The player with the highest score after all seven rounds wins.

G17 Gold Hunting (with options of 006, 009, 012, 015, 018)

The options are the number of times you must find gold to win, see the chart below.

Option	006	009	012	015	018
No. of Times Finding Gold	6	9	12	15	18

The object of the game is to “Find Gold”. You will “Find Gold” when your score reaches exactly 50 or a multiple of 50 (100, 150, 200 etc.). The cricket display will keep track of how many times you find gold. The player who “Finds Gold” the designated amount of times first will win the game. However since gold can make you greedy, whenever you “Find Gold” you will also steal 1 gold from every player who has gold.

To score and attempt to “Find Gold” players take turns throwing darts at the dartboard. The number on the dartboard that you hit will be your score. A double segment is worth double points and a triple is worth triple points.

G18 Killer (with options of -7, -8, -9, -10, -11, -12, -13, =3, =5, =7, =9)

The options are the number of lives you have and what segments to hit for a kill, see the chart below.

Option	-7	-8	-9	-10	-11	-12	-13	=3	=5	=7	=9
No. of Lives	7	8	9	10	11	12	13	3	5	7	9
	Hit Single, Double or Triple to kill							Must hit Doubles only to kill			

To start this game, players throw a dart at the dartboard to select their number. The dartboard display will show SELECT NO. Select your number by throwing a dart at the dartboard. The number selected will be used for that player throughout the game. The number you select will display in your players score display. No two players can select the same number in one game.

To become a “Killer”, a player must hit the double segment in their selected number. Once you become a “Killer” your score display will show - - - during your turn. It will switch back to your selected number during other players turns. Once you become a “Killer” you can then kill other players by hitting the segments of the number they picked until all their “Lives” are killed. Each hit can only “Kill” one “Life” regardless if it is a double or triple. The number of “Lives” remaining will be displayed on the player’s cricket display. The last player with “Lives” will be the winner.

NOTE: For options =3, =5, =7, and =9 you can only kill if you hit a double. A single or triple count as a miss.

G19 Blind Killer (with options of L03, L04, L05, L06, L07, b03, b04, b05, b06, b07)

The options are the number of lives you have and what segments to hit for a kill, see the chart below.

Option	L03	L04	L05	L06	L07	b03	b04	b05	b06	b07
No. of Lives	3	4	5	6	7	3	4	5	6	7
	Players are a “Killer” automatically when the game starts.					Player must hit Bullseye to become a “Killer”				

This game is played like G18 Killer EXCEPT the e-Board Computer will select your number for you. When you start the game the dartboard will display PRE START/NEXT. At this time all players should look away from the dartboard except the player whose turn it is. When the player presses the START/NEXT button the dartboard will display a number for 3 seconds. This is your assigned number that other players must hit the double to “Kill” your lives. This number should be kept a secret from the other players. Players can try to “Kill” any player by hitting double segments of that player’s number.

For the L03-L07 game options, you are automatically a “Killer” when the game starts.

For the b03-b07 options you must hit the bullseye to become a “Killer”. The dartboard will display -25 until you hit the bullseye.

When you “Kill” a life of another player the dartboard will announce “YAY”. The number of lives that players have is kept secret along with the players assigned number. If a player loses all of their lives they are out. The last player with lives left is the winner.

G20 Round-The-Clock (with options of 105, 110, 115, 120)

The options are the last number that will be thrown, see the chart below.

Option	105	110	115	120
Last Number Thrown	5	10	15	20

Players must hit numbers 1 through 5 (or 10, 15, 20) in order. The dartboard will display the number that must be hit. The number can be hit in any segment (single, double or triple). A player has to hit the designated number to move on to the next number. The first player to hit all the designated numbers in order, wins. The scoreboard for each player will display the last number that is to be thrown.

G21 Round-The-Clock Double/Triple (with options of 205, 210, 215, 220, 305, 310, 315, 320)

The options are the last number that will be thrown and the segment that must be hit, see the chart below.

Option	205	210	215	220	305	310	315	320
Last Number Thrown	5	10	15	20	5	10	15	20
	Must hit only Double segments				Must hit only Triple segments			

This game is played the same as Round-The-Clock EXCEPT that only the double (205, 210, 215, 220) or triple (305, 310, 315, 320) segments are used for each number.

G22 Round-The-Clock The Irish Way

The game is played the same as Round-The-Clock EXCEPT that doubles and triples advance you the amount of the double or triple plus one. For example hitting double 1 will move you to number 3.

Once you pass the number 10, the double and triple segments will count as a miss. Also, if you hit a single segment on a number that would put you over 20, it will count as a miss. If you hit a double 10 your next number will be the bullseye. Players must get two bullseyes in the same turn to win the game.

An example of a game played between 2 players is:

Nick	1st Dart	Next #	2nd Dart	Next #	3rd Dart	Next #
1st Turn	S1	2	T2	7	S7	8
2nd Turn	D8	17	S17	18	S5	18
3rd Turn	S18	19	S19	20	S20	Bull
4th Turn	S8	Bull	Bull	2nd Bull	S1	Bull
5th Turn	Double Bull	WINNER!				
Marilyn	1st Dart	Next #	2nd Dart	Next #	3rd Dart	Next #
1st Turn	S1	2	S2	3	S3	4
2nd Turn	D4	9	S9	10	D10	Bull
3rd Turn	Bull	2nd Bull	S17	Bull	D4	Bull
4th Turn	Bull	2nd Bull	S19	Bull	D18	Bull

G23 Nine-Dart Century (with options of 100, 150, 200)

The options are the target score, see the chart below.

Option	100	150	200
Target Score	100 Points	150 Points	200 Points

In this game each player has 9 darts (three turns) to score 100 (or 150, 200) points without going over, or get as close to 100 as possible. If you go over you are “busted” and out of the game. Darts that land outside the scoring area will reset your score back down to zero. Darts that bounce out are not penalized and do not count for any points. The number on the dartboard that you hit will be your score. A double segment is worth double points and a triple is worth triple. The player that gets closest to the Target Score without going over is the winner.

G24 Baseball (with options of B07, B08, B09)

The options are the number of innings, see the chart below.

Option	B07	B08	B09
No. of Innings	7	8	9

A baseball field is laid out as shown in diagram below. A player throws 3 darts in each inning and the runs/bases are set as follows:

Segments	Result
Single	One Base
Double	Two Bases
Triple	Three Bases
Bullseye	Home Run

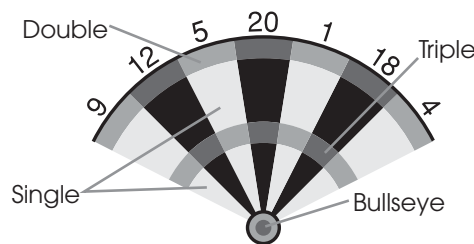

A home run can only be scored on the 3rd dart of each turn. The player with the most runs at the end of the game is the winner.

The cricket display will show the number of innings left and what base your “runners” are on. The table below will show the symbols displayed for the base that your “runner” is on.

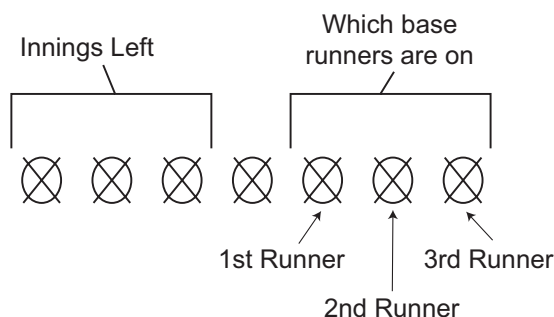

1st Base	2nd Base	3rd Base	Home
\	X	⊗	○

G25 Football

To start the game the dartboard will display SELECT NO. The player will then throw a dart at the dartboard to determine their “number” or “playing field”. Once a “playing field” is selected, you must hit the segments in order from the outside double segment of your number working your way in to the bullseye and to the opposite side to the outer double segment. See illustration and example below. A dart that hits a segment out of their playing field or out of order is a miss.

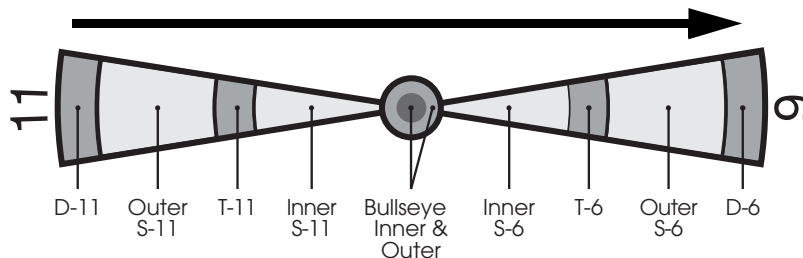

For example, if a player selects segment 11, they have to hit D-11, outer S-11, T-11, inner S-11, outer bullseye, inner bullseye, inner S-6, T-6, outer S-6 and finally D-6. The first player who finishes crossing their playing field is the winner.

G26 Bowling (with options of 10R, 11R, 12R, 13R, 14R, 15R)

Before starting the game you must select the number of players and your desired option. The options are the number of frames, see the chart below.

Option	10R	11R	12R	13R	14R	15R
No. of Frames	10	11	12	13	14	15

For each turn the the dartboard will display SELECT ALLEY. For each turn your first dart will select the “Alley” and the second and third dart will score “pins” or points. Hitting the bullseye will not count as an “Alley” or give you any “pins” or points. “Pins” or points are scored as follows:

Segments	Score
Double	9 Pins
Outer Single	3 Pins
Triple	10 Pins
Inner Single	7 Pins

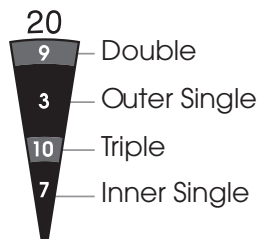

A player cannot hit the same single segment twice in the same frame. The second hit will be counted as zero. You can hit the same triple or double segment twice. However hitting the double segment twice in a row will give you 10 “pins” or points. Hitting the triple segment twice will give you 20 “pins” or points. The player with the highest points or “pins” at the end of the game is the winner. The cricket display will count down the number of frames left. The perfect game is 200/220/240/260/280/300 respectively for the options chosen.

G27 Golf (with options of 09F, 10F, 11F, 12F, 13F, 14F, 15F, 16F, 17F, 18F)

The options are the number of “holes”, see the chart below.

Option	09F	10F	11F	12F	13F	14F	15F	16F	17F	18F
No. of Holes	9	10	11	12	13	14	15	16	17	18

Numbers 1-18 are the “Holes” of the golf course and must be hit in order. Players must hit each number three times before they can move on to the next “hole”. A double will count as two hits, a triple will count as three hits. The e-BOARD Computer will display the best hit for the number you are on. Each dart thrown counts as a “stroke”, whether it hits your designated number or not, and will be displayed on the scoreboard for each player. The cricket display will show how many “holes” are left. The bullseye counts as a miss. The first person to complete all their “holes” wins and the game is over.

G28 Car Racing 1

In this game, the dartboard becomes a race course. The first player to finish the course is the winner. The course begins at the number 20 and runs clockwise around the dartboard to the number 5 triple segment and ends with the bullseye. You must hit the numbers in order clockwise around the dartboard. A valid hit on the course is the inner single. There are 4 obstacles throughout the course at the following segments: triple 13, triple 17, triple 8 and triple 5. The player must hit the triple in each of those numbers to clear the obstacle. The dartboard will display what segment you need to hit and each players scoreboard will display the last number hit. The cricket scoreboard will count down how many segments you need to finish the race.

G29 Car Racing 2

This game is similar Car Racing 1 in that you race around the track, but has a few differences. The track starts at the number 20 and runs clockwise around the dartboard to the number 5. The dartboard will display what number you need to hit. If you hit any single segment for the number you need to hit, it will move your race car one number forward. If you hit a double segment for the number you need to hit, it will move your race car two numbers forward. Likewise a triple will move you 3 numbers forward.

Any time you hit or arrive at the 6, 7, or 12 segments your race car will be moved back 5 spaces.

The cricket board will display how many numbers you have left to finish the race.

You cross the finish line when you land exactly on the number 20. If your throw would move you past the number 20, you will move backward the number of spaces that you went over, starting from the number 20. The one who finishes first is the winner.

G30 Big Six (with options of L-3, L-4, L-5, L-6, L-7)

The options are the number of lives, see the chart below.

Option	L-3	L-4	L-5	L-6	L-7
No. of Lives	3	4	5	6	7

This game allows a player to challenge opponents to hit the targets of the players choice. The dartboard will display the single 6 segment as the first target. Players must earn the chance to pick the next target for their opponent by making a hit on the single 6 target. If they hit the single 6, the dartboard will display SELECT NO. They can then throw a dart to select the next target. That number and segment then becomes the target. The scoreboard will display the target. In any turn if the player does not hit the designated target they loose one life.

If a player hits the target with the first or second dart, the next dart then determines the next target and that players turn is over.

If a player hits the target with the third dart their turn is over and the target stays the same. A life is not lost.

If a player loses all their lives they are out of the game. The remaining players continue the game until one player is left with lives. That player is the winner.

G31 Shove A Penny

This game is similar to Cricket in that you must open numbers 15-20 and the bullseye in order. The dartboard will display which number you have to hit. You must hit each number 3 times to open it. A single segment counts as one hit, a double segment counts as two hits and a triple segment counts as three hits.

Should a player score more than 3 hits in any one number, the excess hits will be given to the next player. The cricket display will keep track of the number of hits per number for each player. The first player to open all their numbers is the winner.

G32 Hi Score (with options of H03, H04, H05, H06, H07, H08, H09, H10, H11, H12)

The options are the number of rounds, see the chart below.

Option	H03	H04	H05	H06	H07	H08	H09	H10	H11	H12
No. of Rounds	3	4	5	6	7	8	9	10	11	12

The rules are simple. A player must rack up the most points in 3, 4, 5...or 12 rounds (each round is 3 darts) to win. Doubles and triples count as 2 times and 3 times that number's score respectively. The cricket display will count down the remaining rounds. The player with the highest score at the end of all the rounds wins.

G33 Double Down

This game starts with a base score of 60 points for each player. There are 9 rounds for each player. Each round has a number or segment that you must hit in order to score. The dartboard will display what number you must hit for that round. The designated numbers for each round are:

Round	1	2	3	4	5	6	7	8	9
Target Number	15	16	Any Double	17	18	Any Triple	19	20	Bullseye

Each dart that hits the correct number will score points based on the number and the segment. For example, if you hit number 15 single segment you will get 15 points. If you hit the number 15 double segment you would get 30 points. If you hit the number 15 triple segment you would get 45 points. If the player does not hit the designated number during their round their score is cut in half and they move on to the next round on their next turn. For the Any Double and Any Triple, the player must hit any double or triple segment. If the doubles and triples are not hit, the players score is cut in half. The player with the highest score after the last round is the winner.

G34 Forty One

This game is the same as Double Down except the sequence for the rounds is reversed from number 20 to the bullseye. The dartboard will display what number you must hit for that round. The designated numbers for each round are:

Round	1	2	3	4	5	6	7	8	9	10
Target Number	20	19	Any Double	18	17	Any Triple	16	15	"41" Points	Bullseye

The additional round of 41 points is included before the bullseye, and a player must hit any 3 segments totalling 41. The player with the highest score after the last round is the winner.

G35 Over (with options of O-7, O-8, O-9)

The options are the number of lives, see the chart below.

Option	O-7	O-8	O-9
No. of Lives	7	8	9

Each player takes a turn throwing 3 darts, the highest score among the players will become the “leader’s score” and the dartboard will announce “LEADER”.

A player’s score will become a new “leader’s score” if his score in the new turn is higher than the previous “leader’s score”. If not, he will lose one life.

If a leader does not want to challenge and wants to keep his “leader’s score”, he can press the START/NEXT button and skip his turn. A leader can choose to challenge his own “leader’s score” but he will also lose a life if his new score is lower than the leader’s score.

The Cricket Display will show how many “Lives” each player has. After a player throws, if they do not have a new “leader’s score”, a life will be lost. If their score is higher than the “leader’s score”, then the e-BOARD Computer will announce “LEADER” and keep his score. The current “leader’s score” is displayed on the scoreboard.

If a player loses all their lives they are out of the game. The remaining players continue the game until one player is left with lives. That player is the winner.

G36 Under (with options of U-7, U-8, U-9)

The options are the number of lives, see the chart below.

Option	U-7	U-8	U-9
No. of Lives	7	8	9

The rules follow exactly as Over except the “leader’s score” is the lowest score for each turn. A missed dart will be counted as 60.

G37 All Fives (with options of 551, 561, 571, 581, 591)

The options are the total points you need to win, see the chart below.

Option	551	561	571	581	591
Total Points	51	61	71	81	91

During each round the player’s total score for that round must be divisible by 5. Every divisible 5 counts as one point. For instance, 2, 8, 5 totals 15. A player will get 3 points as 15 divided by 5 equals 3. There will be no points if the round of 3 darts’ total score is not divisible by 5. The e-BOARD Computer will display the best possible hit for your third dart, that will give you the most points. The first player to score 51, 61, 71, 81, or 91 will be the winner.

G38 Leg (with options of L03, L04, L05)

The options are the number of leg's, see the chart below.

Option	L03	L04	L05
No. of Leg's	3	4	5

Each player will begin with 3 (or 4,5) "leg's". Players will take turns throwing three darts. Each player must beat the previous players score, or they will loose a "leg". The last player who still has a "leg" left will win.

ONE YEAR LIMITED WARRANTY

The Manufacturer warrants to the original retail purchaser that this product is free from defects in material and workmanship under normal use and conditions for a period of one year from the date of original purchase. The Manufacturer's liability is limited to the repair or replacement, at its option, of any defective product and shall not include any liability for indirect, incidental or consequential damages of any kind.

Should this product become defective due to material or workmanship within the warranty period, contact our Customer Service Department. This warranty is not transferable and does not cover normal wear and tear or damage caused by improper usage, negligence, misuse, abuse, transportation damage, acts of nature, or accident (including failure to follow the instructions in this manual). It does not cover expendable items such as batteries, light bulbs, fuses, accessories, cosmetic parts and other items that wear out due to normal usage. This warranty is also void if the product is disassembled and reassembled, damaged, modified from its original state, or used for other than indoor personal residential use (no commercial or rental applications).

This warranty gives you specific legal rights, and you may have other rights which vary from state to state.

IF YOU HAVE A WARRANTY CLAIM, CALL US FIRST (8 - 4:30 CST)

Please have your receipt and item number (found on the front cover) when you call.

GLD Products

S84 W19093 Enterprise Drive
Muskego, WI 53150 USA
1-800-225-7593 ext 113
Fax: 1-800-841-6944
Email: gld@gldmfg.com
Web: www.gldproducts.com
Web: www.GLDProducts.com

If you are instructed to return the product for service, you are responsible for shipping the unit at your expense to the above address in packaging that will protect against further damage. All warranty or repair requests require a Return Authorization Number prior to returning the item.

PRODUCT REGISTRATION

Important: The product registration form on page 35 must be completed and returned along with a copy of your receipt within 10 days of purchase to validate your warranty.

REGISTER YOUR PRODUCT

Place postage here

Complete this form, include a copy of your receipt, fold, tape (do not staple) and return within 10 days of purchase. This protects your warranty and will help us develop new products!

Cut here.

GLD Products
 Warranty Department
 S84 W19093 Enterprise Drive
 Muskego, WI 53150 USA

Fold here second.



www.gldproducts.com

- | | |
|-----------------------|----------------------------|
| GAME TABLES | HOME CASINO |
| GAMES AND ACCESSORIES | BILLIARD CUES |
| BILLIARD ACCESSORIES | DARTBOARDS |
| SOFT-TIP DARTS | STEEL-TIP DARTS |
| FLIGHTS AND SHAFTS | DART CASES AND ACCESSORIES |

Fold here first.

Name	Date of Purchase
Address	Phone-Day
City	Phone-Evening
State Zip	Email
Purchase Price:	Item: 42-1022 X-treme Dartboard
Store Name:	

1. What are the top two reasons that influenced the purchase of this product? Select two.

- | | | | |
|--------------------------|-------------------------|--------------------------|---|
| <input type="checkbox"/> | Brand reputation | <input type="checkbox"/> | Prior experience with another GLD product |
| <input type="checkbox"/> | Saw in an advertisement | <input type="checkbox"/> | Color/appearance |
| <input type="checkbox"/> | Quality/durability | <input type="checkbox"/> | Other |
| <input type="checkbox"/> | Value for price | | |

2. How did you become aware of this product? Select two.

<input type="checkbox"/>	Saw in an advertisement	<input type="checkbox"/>	Saw it in the store
<input type="checkbox"/>	Saw or used a friend's or relative's	<input type="checkbox"/>	Recommended by another person
<input type="checkbox"/>	Received as a gift	<input type="checkbox"/>	Other

3. Rate your satisfaction with each of the following?

	Excellent	Good	Fair	Poor
Assembly instructions				
Ease of assembly				
Packaging				
Overall product satisfaction				

4. Were there any parts missing?

Yes No If so, which ones? Order No. _____

5. Based on your experience, would you buy another GLD product?

Yes No

6. Is this the first GLD product that you've owned? If No, what other product have you owned?:

Yes No _____

7. Have you owned products from:

Sportcraft Harvard Classic Sport Other

8. When did you decide to purchase this product?

Before entering the store. While in the store/impulse purchase

9. How many times per month will you use it?

1 to 3 4 to 8 9 to 15 16 +

10. Are you the intended user of this product?

Yes No, indicate who: _____

11. Where will you use this product?

Home Other: _____

12. Please tell us your gender?

Male Female

13. And your marital status?

Married Single

14. Age?

Under 25 25 - 40 40 - 60 Over 60

15. Which best describes your family income?

<input type="checkbox"/>	Under \$25,000	<input type="checkbox"/>	\$25,000 - \$49,999	<input type="checkbox"/>	\$50,000 - \$99,999
<input type="checkbox"/>	\$100,000 - 149,999	<input type="checkbox"/>	\$150,000 - \$199,999	<input type="checkbox"/>	Over \$200,000

16. Education:

<input type="checkbox"/>	Some high school	<input type="checkbox"/>	College degree
<input type="checkbox"/>	Completed high school	<input type="checkbox"/>	Graduate degree

Remember to attach a copy of your receipt.

Mail To: GLD Products
 S84 W19093 Enterprise Drive
 Muskego, WI 53150 USA
 1-800-225-7593 • FAX 800-841-6944
 Email: gld@gldmfg.com
 Web Site: www.gldproducts.com

X-treme Dartboard

Item 42-1022

Parts Re-Order Form

Name		Date
Address		Phone-Day
City		Phone-Evening
State	Zip	Email

Order No.	Description	Unit Price	Qty.	Total Amount
6-19	500 mA Adapter	15.00		
6-44	2 Piece Bullseye, Nylon	15.00		
6-45	Pie Section, Black and Red Segments, Nylon	20.00		
6-46	Pie Section, Grey and Red Segments, Nylon	20.00		
6-15	Set of 3 Soft Tip Darts	5.00		
37-1652-01	Tips, 100 pcs	4.99		
6-38	Aluminum Shafts 3 pc	3.00		
6-11	Mounting Hardware	3.00		
6-14	Flights 3 pc, designs vary	1.50		
		Subtotal		
Shipping will be added. If paid by Check or Money Order, call for quote.		S/H		
5.1% Waukesha Wisconsin tax will apply (subject to change).		Tax		
		Total		

Method of Payment

Check or Money Order
 Credit Card
 Visa MasterCard Discover American Express
 Card # _____
 Security Code # _____ Billing Address Zipcode _____
 Signature _____ Exp. Date _____

Shipping Address

Name _____
 Address _____ Phone _____
 City _____ State _____ Zip _____



www.gldproducts.com

GAME TABLES

HOME CASINO

GAMES AND ACCESSORIES

BILLIARD CUES

BILLIARD ACCESSORIES

DARTBOARDS

SOFT-TIP DARTS

STEEL-TIP DARTS

FLIGHTS AND SHAFTS

DART CASES AND ACCESSORIES



PROUD MANUFACTURER OF



S84 W19093 Enterprise Drive • Muskego, WI 53150 USA
262.679.8730 or 1.800.225.7593 tele
262.679.8738 or 1.800.841.6944 fax
262.679.8739 international fax
Email: gld@gldmfg.com
www.gldproducts.com