

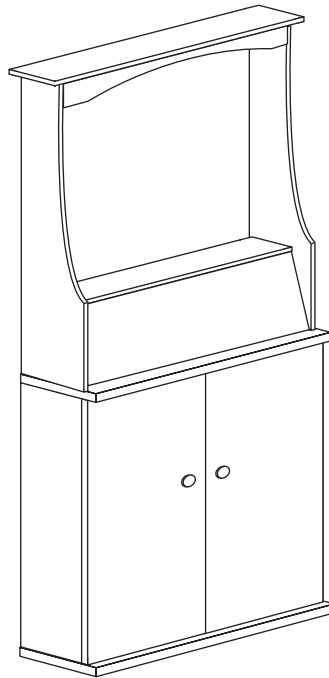

**Stand Up
Dart Board Cabinet**

Item 40-0269

STAND UP DART BOARD CABINET



Replacement Parts

Order direct at www.gldproducts.com
or call our Customer Service department at
(800) 225-7593
8 am to 5 pm Central Standard Time

Staple your receipt here.

Important: A copy of your receipt will be needed to activate your warranty (see page 15).

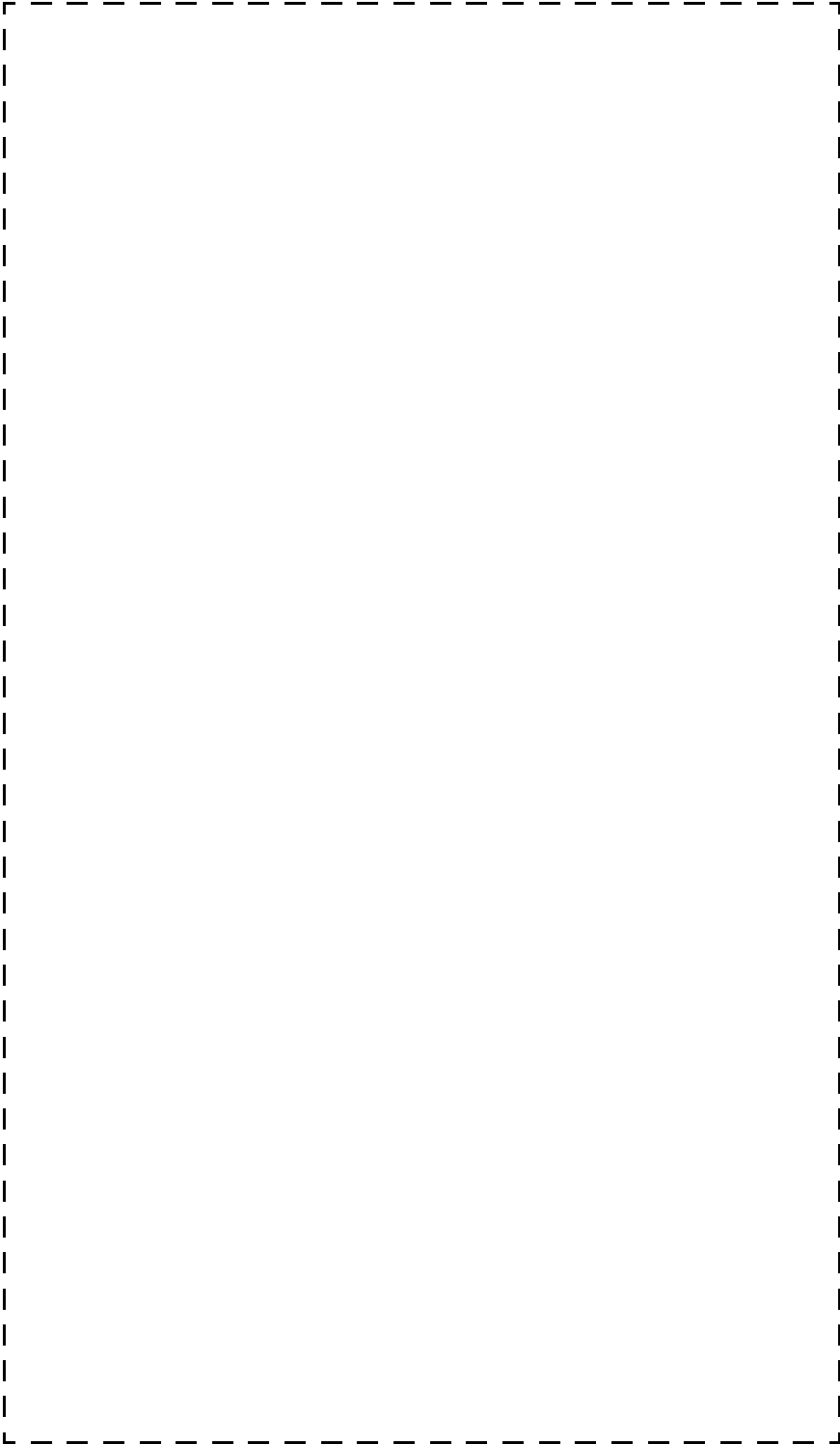



Congratulations and THANK YOU for purchasing the Stand Up Dart Board Cabinet. You have chosen a product that should provide years of entertainment. To assist you with customer service and warranty claims, staple your receipt to the inside cover, then keep this manual in a safe place for future reference.

GLD Products











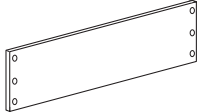
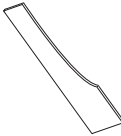
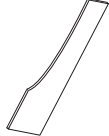

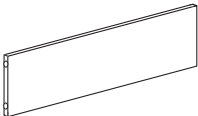
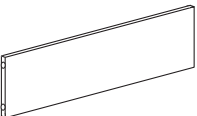
S84 W19093 Enterprise Drive
Muskego, WI 53150 USA
1-800-225-7593
Fax: 1-800-841-6944
Email: gld@gldmfg.com
Web: www.gldproducts.com

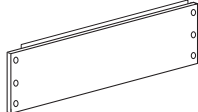
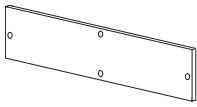
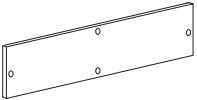

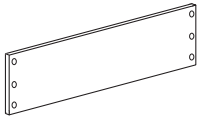

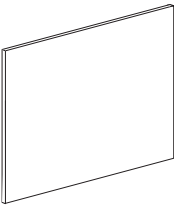
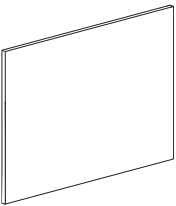

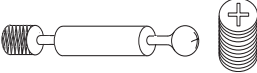

This manual may have been updated. For the latest manual visit the GLD Products website.

	<p>Place your package near the location where it will be used. Carefully unpack all components and verify you have all the correct pieces.</p> <p>If you notice missing or defective parts, please call us at: 1-800-225-7593.</p>
---	---

	<p>Please read and understand all instructions before beginning assembly.</p> <p>This product is not for use by children without adult supervision.</p>
---	---

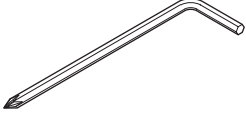
Parts Identifier

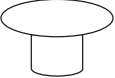
Part No./ Qty	Illustration/ Order Number	Part No./ Qty	Illustration/ Order Number	Part No./ Qty	Illustration/ Order Number
1 Qty. 1	 Top Board Order No. 7-1	2 Qty. 1	 Side Board Left Upper Cabinet Order No. 7-2	3 Qty. 1	 Side Board Right Upper Cabinet Order No. 7-3
4 Qty. 1	 Top Support Board Order No. 7-4	5 Qty. 1	 Bottom Support Board Upper Cabinet Order No. 7-5	6 Qty. 1	 Support Board Lower Cabinet Order No. 7-6
7 Qty. 1	 Shelf Door Order No. 7-7	8 Qty. 1	 Middle Board Order No. 7-8	9 Qty. 1	 Side Board Left Lower Cabinet Order No. 7-9
10 Qty. 1	 Side Board Right Lower Cabinet Order No. 7-10	11 Qty. 7	 3.5 x 30 mm Round Head Screw Order No. 7-11	12 Qty. 1	 Bottom Lower Cabinet Order No. 7-12
13 Qty. 2	 Cabinet Door Order No. 7-13	14 Qty. 1	 Upper Back Board Order No. 7-14	15 Qty. 1	 Lower Back Board Order No. 7-15
16 Qty. 4	 Lower Door Hinge Order No. 7-16	17 Qty. 8	 3.5 x 12 mm Round Head Screw Order No. 7-17	18 Qty. 12	 3.5 x 10.5 mm Flat Head Screw Order No. 7-18

<p>19</p>  <p>Qty. 22</p> <p>3.5 x 21 mm Flat Head Screw Order No. 7-19</p>	<p>20</p>  <p>Qty. 8</p> <p>Connector Assy. Order No. 7-20</p>	<p>21</p>  <p>Qty. 28</p> <p>Plastic Dowel Order No. 7-21</p>
<p>22</p>  <p>Qty. 8</p> <p>4 x 12 mm Round Head Screw Order No. 7-22</p>	<p>23</p>  <p>Qty. 2</p> <p>Shelf Hinge Order No. 7-23</p>	<p>24</p>  <p>Qty. 1</p> <p>Allen Wrench Order No. 7-24</p>
<p>25</p>  <p>Qty. 7</p> <p>Wall Anchor Order No. 7-25</p>	<p>26</p>  <p>Qty. 2</p> <p>Knob Order No. 7-26</p>	<p>27</p>  <p>Qty. 2</p> <p>4 x 18 mm Round Head Bolt Order No. 27</p>

IF YOU HAVE A WARRANTY CLAIM, CALL US FIRST

Refer to page 15.

GLD Products

Available 8 am to 5 pm Central Standard Time

S84 W19093 Enterprise Drive
Muskego, WI 53150 USA

1-800-225-7593

Fax: 1-800-841-6944

Email: gld@gldmfg.com

Web: www.gldproducts.com

For all claims, please have your receipt and item number when you call. The product item number can be found on the front cover.

If you are instructed to return the product for service, you are responsible for shipping the unit at your expense.

PRODUCT REGISTRATION

Important: The product registration form on page 17 and a copy of your receipt must be completed and returned within 10 days of purchase to validate your warranty.

Preparing for Assembly

- Be sure to unpack all of the parts included in this package. Some parts may be in obscure locations of the packaging. Check inside any tubes or sleeves. Save all packing material until the product is fully assembled and functional.
- Compare the parts in your package with the Parts Identifier description on pages 4 and 5.

Tools Required

- Allen wrench (#24) - included with table
- Phillips screwdriver (not included)
- Level (not included)
- Small Hammer
- Electric screwdriver may be helpful. **CAUTION:** You must set at **LOW TORQUE** and use extreme caution because you could overtighten the hardware, strip the screws, or damage the table.

Assembly Tips

Make sure you understand the following before you begin to assemble your game table.

1. READ THIS MANUAL all the way through before beginning assembly.
2. When installing parts that have more than one bolt, start ALL bolts in that part by hand before tightening anything.
3. Some drawings or images in this manual may not look exactly like your product.

Note: Save all packing materials until the parts have been inspected and the table is assembled.

Unpack the Pieces

- Lay the box on a flat surface (floor). You may want this near your area of assembly.
- Unpack the boxes and part bags. Inspect and count the parts. The Parts Identifier page can be used to record your results.
- If any parts are damaged or missing contact GLD customer service.
- Missing fasteners may be purchased at a hardware store using the descriptions on the Parts Identifier page(s).

STEP 1 - ASSEMBLE THE TOP FRAME

1. Assemble the shelf door (#7) to the middle board (#8) using the shelf hinge (#23) and the round head screws (#17).

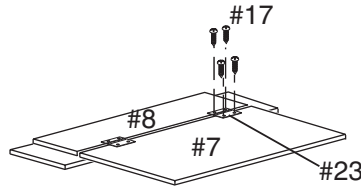

2. Position the top board (#1), side board left (#2), side board right (#3), top support board (#4), and bottom support board (#5).

NOTE: The boards may have finished and unfinished surfaces. Be certain the boards are facing correctly before assembly.

3. Each connection joint will have two plastic dowels (#21) inserted. Use a small hammer to tap the plastic dowels into the predrilled holes.
4. Connect the top support board (#4) and the bottom support board (#5) into the side boards (#2 and #3).

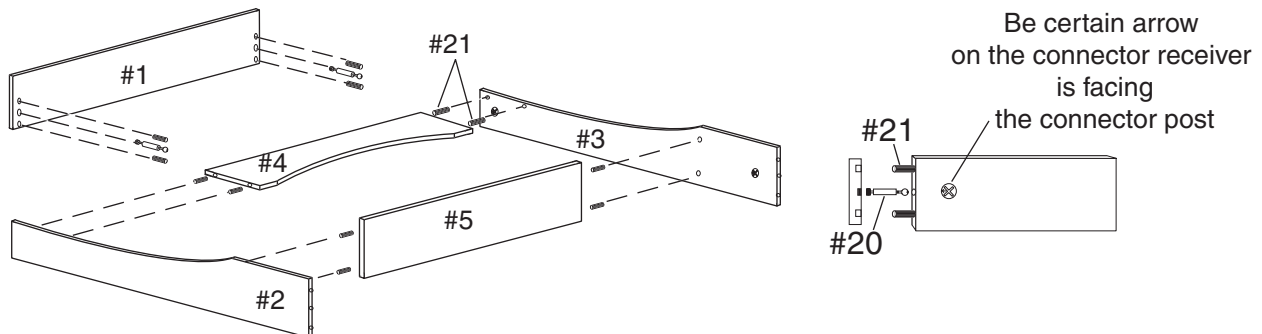

5. Connect the top board (#1) to the side boards (#2 and #3) using plastic dowels (#21) and the connector assembly (#20). Insert the connector receiver into the hole on the side of the side board. Be certain the arrows on connector receiver are facing toward the connector posts.
6. The two side boards will lock with the top board using the connector assembly (#20). Screw the connector post into the predrilled holes in the top board. Do not over tighten. Insert the connector receiver into the hole on the side of the side board. The cross should be visible with the small arrow pointing toward the post.

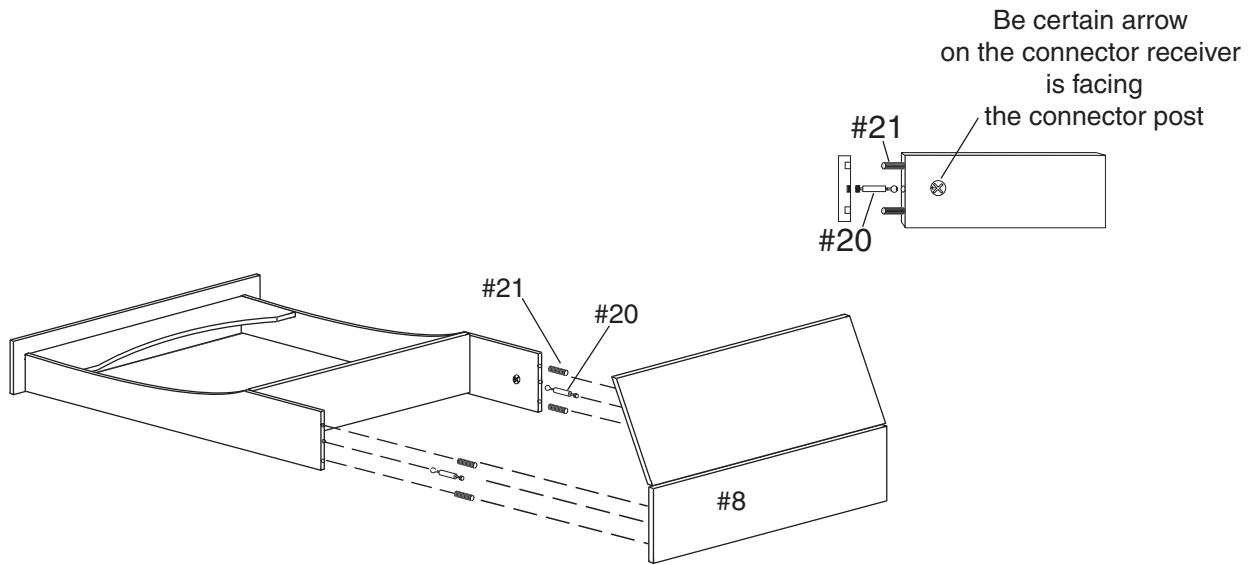

7. Press together completely. Use a phillips screwdriver to turn the receiver clockwise to lock in the post. Inspect the joints and positions of the pieces.

STEP 2 - ASSEMBLE THE LOWER CABINET

1. Layout the side board left (#9) and side board right (#10). Place the support board lower cabinet (#6) and the bottom lower cabinet (#12) in place.
2. Insert two plastic dowels (#21) in both ends of support board (#6) and the bottom end of both side boards. Tap in place with a small hammer.
3. Position the support board between the two side boards. Match-up finished surfaces and press the support board into the side boards.
4. The connection of the two side boards with the bottom board uses connector assemblies (#21).
5. Screw the connector assembly posts into the bottom board.
6. Insert the connector assembly receivers into the side boards. The slotted cross should be visible and the small arrow should point towards the post.
7. Push the bottom board in place.
8. When the boards are seated use a phillips screwdriver to turn the receivers clockwise to tighten.

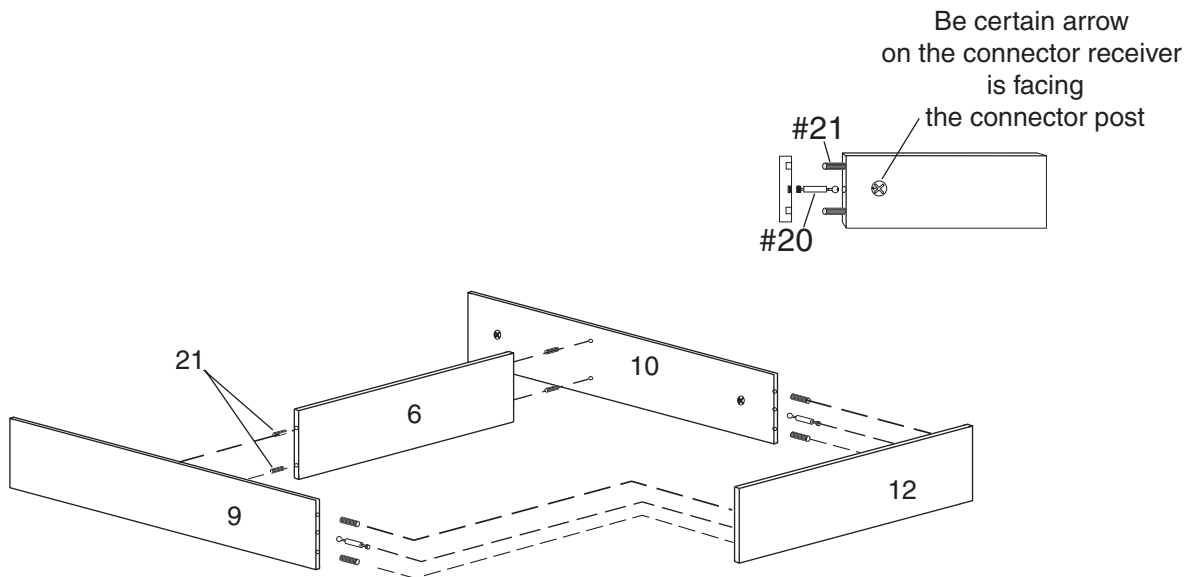

STEP 3 - ASSEMBLE LOWER TO UPPER CABINET

Both cabinets should be face up. Check all boards for correct placement of finished edges.

1. Insert plastic dowels (#21) into the bottom of the middle board. Tap in place with a small hammer.
2. Screw connector assembly posts (#20) into the middle board.
3. Insert connector assembly receivers into the holes in the side boards. The arrow should point to the posts.
4. Push the two assemblies together and tighten the connector assembly receivers with a phillips screwdriver.

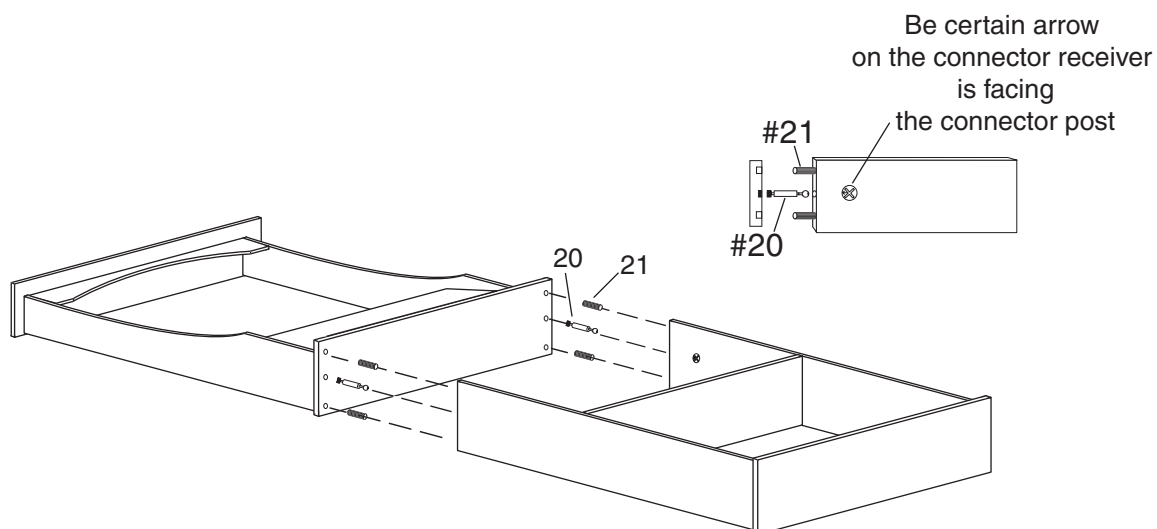

STEP 4- ATTACH THE BACK BOARDS

1. Roll the assembly over (face down on the floor).
2. Place the upper (#14) and lower (#15) boards onto the back of the cabinet. The finished sides should be down.

Before screwing the back boards in place be certain the cabinet is square. Measure diagonally from corner to corner. Adjust the cabinet until the measurements are the same.

3. Position the boards so they are even side to side and top to bottom.
4. Secure one end of a back board with two screws (#19). Check squareness and put two screws into the other end of the back board.
5. Secure the second back board with screws.
6. Finish screwing the back boards to the cabinet.

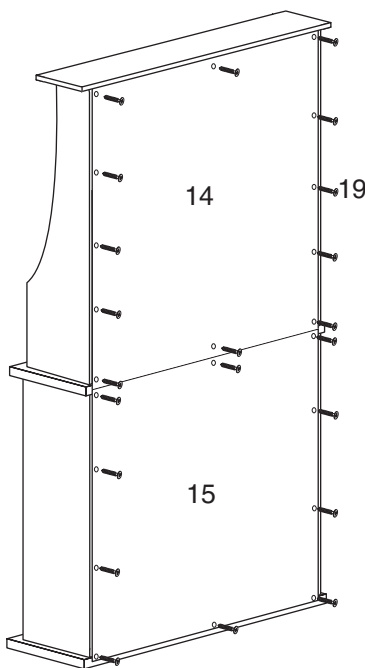

STEP 5 - ATTACH LOWER CABINET DOORS

1. Stand the cabinet assembly up and against a wall. It should lean back slightly to help prevent it from falling over.
2. Lay the two cabinet doors (#13) face down.
3. Attach lower door hinges (#16) to the doors using screws (#18). The side of the hinge with the three holes attaches to the door.
4. Hold the door in place and use screws (#22) to secure the hinge to the side board.

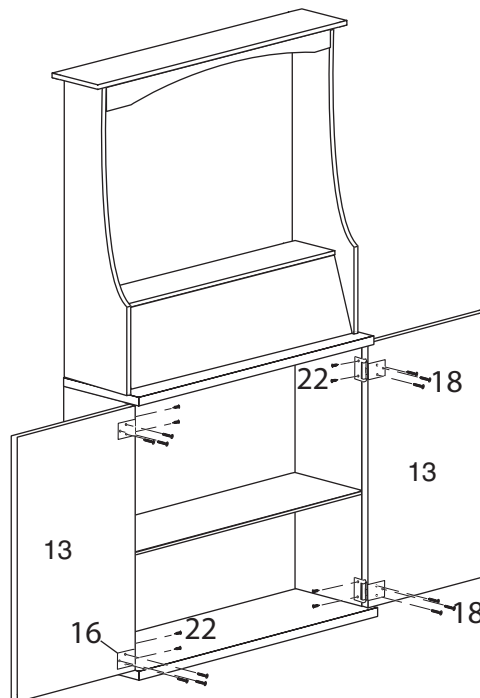

STEP 6 - MOUNT CABINET TO WALL

1. Position the cabinet where it will be used. The throwing line will be 96 inches away from the dart board. Allow 10 feet of room for players to throw darts.
2. Push the cabinet against the wall.
3. Mark fastener locations on the wall through holes in the back board.
4. Drill holes in the wall to accept the wall anchors (#25). If any screws are going into wall studs get proper screws for those holes.
5. Move cabinet back in position and use screws (#11) and a phillips screwdriver to secure the cabinet to the wall.

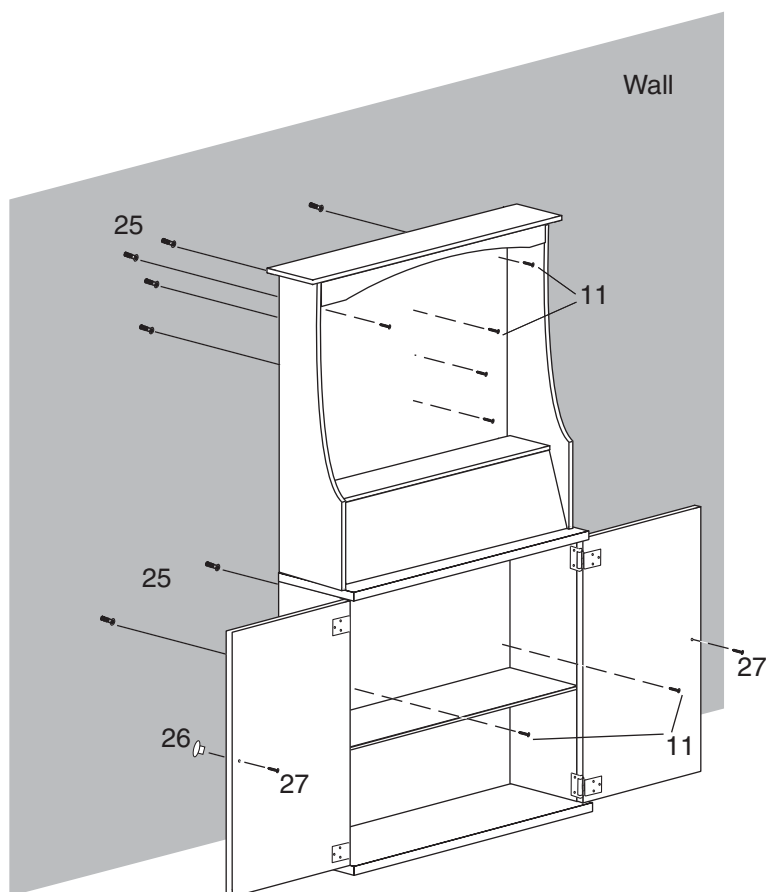

6. Attach knob (#26) to cabinet door using bolt (#27).

90-DAY LIMITED WARRANTY

The Manufacturer warrants to the original retail purchaser that this product is free from defects in material and workmanship under normal use and conditions for a period of ninety (90) days from the date of original purchase. The Manufacturer's liability is limited to the repair or replacement, at its option, of any defective product and shall not include any liability for indirect, incidental or consequential damages of any kind.

Should this product become defective due to material or workmanship within the warranty period, contact our Customer Service Department. This warranty is not transferable and does not cover normal wear and tear or damage caused by improper usage, negligence, misuse, abuse, transportation damage, acts of nature, or accident (including failure to follow the instructions in this manual). It does not cover expendable items such as batteries, light bulbs, fuses, accessories, cosmetic parts and other items that wear out due to normal usage, including areas of the playing surface. This warranty is also void if the product is disassembled and reassembled, damaged, modified from its original state, or used for other than indoor personal residential use (no commercial or rental applications).

This warranty gives you specific legal rights, and you may have other rights which vary from state to state.

IF YOU HAVE A WARRANTY CLAIM, CALL US FIRST (8 - 5 CST)

Please have your receipt and item number (found on the front cover) when you call.

GLD Products

S84 W19093 Enterprise Drive
Muskego, WI 53150 USA
1-800-225-7593
Fax: 1-800-841-6944
Email: gld@gldmfg.com
Web: www.gldproducts.com

If you are instructed to return the product for service, you are responsible for shipping the unit at your expense to the above address in packaging that will protect against further damage. All warranty or repair requests require a Return Authorization Number prior to returning the item.

PRODUCT REGISTRATION

Important: The Product Registration form on page 17 must be completed and returned along with a copy of your receipt within 10 days of purchase to validate your warranty.

REGISTER YOUR PRODUCT

Place postage here

Complete this form, include a copy of your receipt, fold, tape (do not staple) and return within 10 days of purchase. This protects your warranty and will help us develop new products!

Cut here.

GLD Products
Warranty Department
S84 W19093 Enterprise Drive
Muskego, WI 53150 USA

Fold here second.



P R O D U C T S

www.gldproducts.com

GAME TABLES	HOME CASINO
GAMES AND ACCESSORIES	BILLIARD CUES
BILLIARD ACCESSORIES	DARTBOARDS
SOFT-TIP DARTS	STEEL-TIP DARTS
FLIGHTS AND SHAFTS	DART CASES AND ACCESSORIES

Fold here first.

Name	Date of Purchase
Address	Phone-Day
City	Phone-Evening
State Zip	Email
Purchase Price:	Item: 42-0269 Stand Up Dart Board Cabinet
Store Name:	

1. What are the top two reasons that influenced the purchase of this product? Select two.

<input type="checkbox"/>
<input type="checkbox"/>
<input type="checkbox"/>
<input type="checkbox"/>

Brand reputation
Saw in an advertisement
Quality/durability
Value for price

<input type="checkbox"/>
<input type="checkbox"/>
<input type="checkbox"/>

Prior experience with another GLD product
Color/appearance
Other

2. How did you become aware of this product? Select two.

Saw in an advertisement
Saw or used a friend's or relative's
Received as a gift

Saw it in the store
Recommended by another person
Other

3. Rate your satisfaction with each of the following?

Assembly instructions
Ease of assembly
Packaging
Overall product satisfaction

Excellent	Good	Fair	Poor

4. Were there any parts missing?

Yes

No

If so, which ones?

Order No. _____

5. Based on your experience, would you buy another GLD product?

Yes

No

6. Is this the first GLD product that you've owned? If No, what other product have you owned?:

Yes

No

7. Have you owned products from:

Sportcraft

Harvard

Classic Sport

Other

8. When did you decide to purchase this product?

Before entering the store.

While in the store/impulse purchase

9. How many times per month will you use it?

1 to 3

4 to 8

9 to 15

16 +

10. Are you the intended user of this product?

Yes

No, indicate who: _____

11. Where will you use this product?

Home

Other: _____

12. Please tell us your gender?

Male

Female

13. And your marital status?

Married

Single

14. Age?

Under 25

25 - 40

40 - 60

Over 60

15. Which best describes your family income?

Under \$25,000

\$25,000 - \$49,999

\$50,000 - \$99,999

\$100,000 - 149,999

\$150,000 - \$199,999

Over \$200,000

16. Education:

Some high school

College degree

Completed high school

Graduate degree

Remember to attach a copy of your receipt.

Mail To: GLD Products
 S84 W19093 Enterprise Drive
 Muskego, WI 53150 USA
 1-800-225-7593 • FAX 800-841-6944
 Email: gld@gldmfg.com
 Web Site: www.gldproducts.com

Stand Up Dart Board Cabinet

Item 40-0269

Parts Re-Order Form

Name		Date
Address		Phone-Day
City		Phone-Evening
State	Zip	Email

Order No.	Description	Unit Price	Qty.	Total Amount
7-1	Top Board	5.00		
7-2	Side Board Left Upper Cabinet	5.00		
7-3	Side Board Right Upper Cabinet	5.00		
7-4	Top Support Board	5.00		
7-5	Bottom Support Board Upper Cabinet	5.00		
7-6	Support Board Lower Cabinet	5.00		
7-7	Shelf Door	5.00		
7-8	Middle Board	5.00		
7-9	Side Board Left Lower Cabinet	5.00		
7-10	Side Board Right Lower Cabinet	5.00		
7-11	3.5 x 30 mm Round Head Screw	1.00		
7-12	Bottom Lower Cabinet	5.00		
7-13	Cabinet Door	5.00		
7-14	Upper Back Board	20.00		
7-15	Lower Back Board	20.00		
7-16	Lower Door Hinge	1.00		
7-17	3.5 x 12 mm Round Head Screw	1.00		
7-18	3.5 x 10.5 mm Flat Head Screw	1.00		
7-19	3.5 x 21 mm Flat Head Screw	1.00		
7-20	Connector Assy.	1.00		
7-21	Plastic Dowel	1.00		
7-22	4 x 12 mm Round Head Screw	1.00		
7-23	Shelf Hinge	1.00		
7-24	Allen Wrench	1.00		
7-25	Wall Anchor	1.00		
7-26	Knob	1.00		
7-27	4 x 18 mm Round Head Bolt	1.00		
		Subtotal		
Shipping will be added. If paid by Check or Money Order, call for quote.		S/H		
5.1% Waukesha Wisconsin tax will apply (subject to change).		Tax		
		Total		

Method of Payment

_____ Check or Money Order

_____ Credit Card

_____ Visa _____ MasterCard _____ Discover _____ American Express

Card # _____

Security Code # _____ Billing Address Zipcode _____

Signature _____ Exp. Date _____

Shipping Address

Name _____

Address _____ Phone _____

City _____ State _____ Zip _____



www.gldproducts.com

GAME TABLES

HOME CASINO

GAMES AND ACCESSORIES

BILLIARD CUES

BILLIARD ACCESSORIES

DARTBOARDS

SOFT-TIP DARTS

STEEL-TIP DARTS

FLIGHTS AND SHAFTS

DART CASES AND ACCESSORIES



PROUD MANUFACTURER OF



S84 W19093 Enterprise Drive • Muskego, WI 53150 USA
262.679.8730 or 1.800.225.7593 tele
262.679.8738 or 1.800.841.6944 fax
262.679.8739 international fax
Email: gld@gldmfg.com
www.gldproducts.com