

Model # 64-1018

Easy Assembly & Instructions

3-IN-1 CONVERSION TOP

PING PONG • BACKGAMMON • CHECKERS



Congratulations on your purchase of the Fat Cat™ Ping Pong Conversion Top!

This manual is provided to instruct you during the assembly of your new Fat Cat™ Ping Pong Conversion Top. Please refer to it as necessary.

Careful handling of all parts during assembly will ensure many years of enjoyment!

Playing surface dimensions: 84" x 42 1/2" Fits standard pool table.

Assembling Your Ping Pong Conversion Top

Step 1. Unfolding the game table

Unfold (#1) playing surface and place on level table, playing side up.

Step 2. Attaching the net clips to the playing surface

Slide (#3) net bracket onto playing surface at center left. Slide net bracket onto playing surface at center right.

Step 3. Assembling the net

Unfold (#2) net and slide elastic loops onto left (#3) net bracket. Stretch net across center of table and slide elastic loops onto right net bracket. **You are now ready to play!**

Warning to Parents:

Please read instructions carefully. Not for use by children without adult supervision.

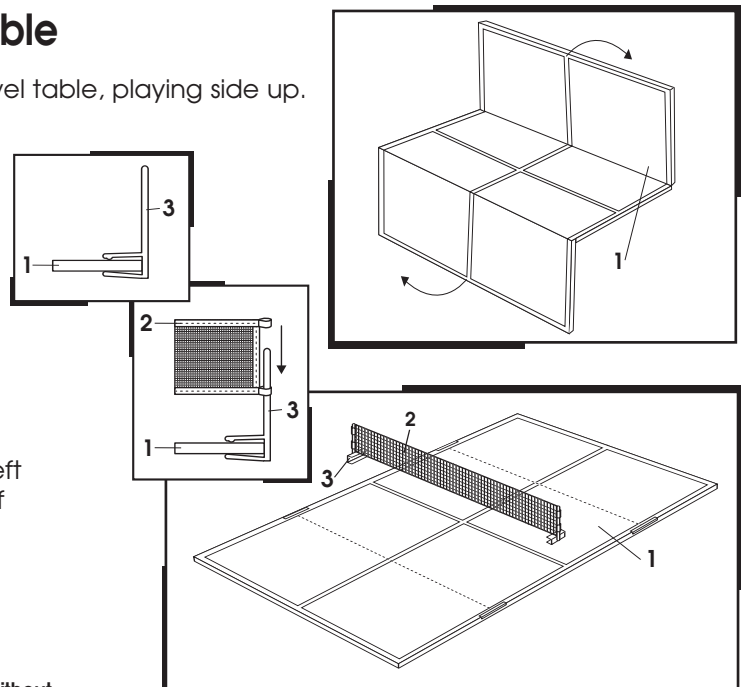

3-in-1 Conversion Top Parts List

<p>#1</p>  <p>Playing Surface 1 piece</p>	<p>#2</p>  <p>Net 1 piece</p>	<p>#3</p>  <p>Net Bracket 2 pieces</p>	<p>#4</p>  <p>Ball 3 pieces</p>
<p>#5</p>  <p>Paddle 2 pieces</p>	<p>#6</p>  <p>Nylon Carrying Bag 1 piece</p>	<p>#7</p>  <p>Red Chips 30 pieces</p>	<p>#8</p>  <p>Black Chips 30 pieces</p>

WARRANTY INFORMATION

90 Day Warranty on 3-in-1 Conversion Top

Manufacturer warrants to the original retail purchaser, this product to be free from defects in material and workmanship for a period of ninety (90) days from the date of purchase.

Should this product become defective due to material or workmanship within the warranty period, contact our Customer Service Department. This warranty is not transferable and does not cover normal wear and tear, or damage caused by improper handling, installation or use of this product. This warranty is also void if product is in any way abused, damaged, or modified from its original state, or if used for other than indoor residential use. This warranty gives you specific legal rights, and you may have other rights which vary from state to state.

DO NOT RETURN TO STORE

For all returns and warranty coverage, please visit our website at www.gldmfg.com or call 1-800-225-7593.

Please provide model number, serial number and/or part number when you call. Numbers can be found on outside of packaging.

WARNING TO PARENTS:

Please read instructions carefully. Not for use by children without adult supervision.



GLD Products

S84 W19093 Enterprise Drive
Muskego, WI 53150 USA
800 225 7593 • FAX 800 841 6944
Email: gld@gldmfg.com